

CE 573 – Structural Dynamics

Homework #3

due 24 September 2009, Friday, 1:30pm

- 1) The single-story structure shown below can be modeled simply as a single-degree-of-freedom system by regarding the roof as a rigid slab and columns as massless flexible supports clamped at both ends. Let the roof slab mass be m and the flexural constant of the columns be equal to EI .
 - a. Find the natural period for horizontal motion of the structure.
 - b. If the foundation of the building undergoes a horizontal motion defined by $x_g(t) = x_0 \sin(\omega \cdot t)$, what will be the response of the building? Find the closed form algebraic expression describing the displacement response of the structure.

Aside: Are inertial forces associated with absolute acceleration or relative acceleration?

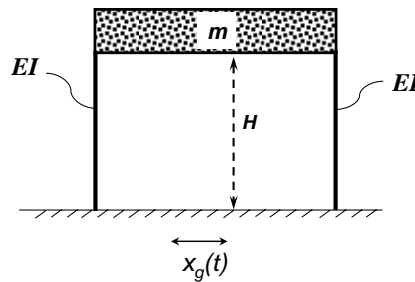

- 2) On a nice weekend day, while you are riding your bicycle around in West Lafayette you make a wrong turn and end up riding on the infamously rough Lindberg Road by the Celery Bog. The Lindberg Road surface level varies harmonically with ± 6 cm undulations about the level surface elsewhere. The distance between consecutive peaks of these undulations is measured to be 2 m.

Assume that all of the “suspension” in your bike is thanks to two springs under the seat of your bike. When you sit on the seat of your bike for your casual ride, the springs deflect 5 cm. When you are seated, the damper under the seat provides an equivalent linear viscous damping of 10% of the critical damping.

A simple representation of your ride on the “never-ending” rough road is shown below.

- a. If you are riding your bicycle at a horizontal speed v of 2.5 m/sec, how much bumping up and down will you experience? In other words, what is the maximum vertical displacement you will experience?
- b. On another Lindberg Road bike ride, you are carrying a backpack which increases your on-seat weight by 20%. Assuming that you are still able to ride at $v = 2.5$ m/sec, will this “loaded” ride be more or less comfortable than your previous one, i.e. the ride without the backpack?

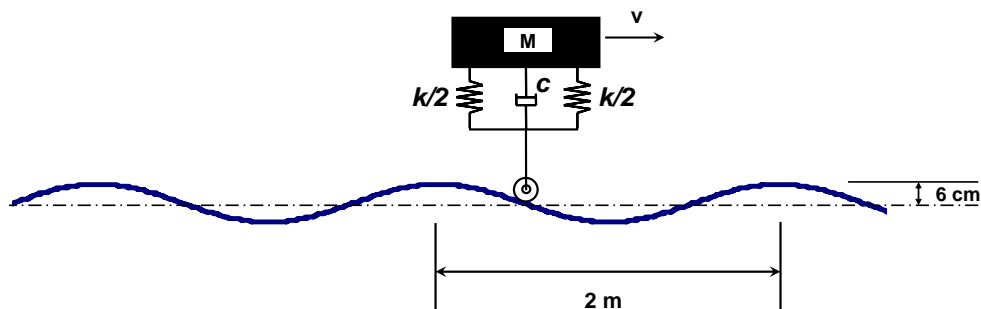

- 3) The 3-story flat-plate reinforced concrete structure in the Bowen Lab was subjected to a series of forced vibration tests to estimate the fundamental mode period and corresponding damping ratio of the structure. The harmonic forcing on the building was provided via an actuator installed at the roof of the building. The dynamic-mass, i.e. the moving part, of the actuator was 700 lb (unit is for mass, not weight!). Experimenters were able to move this mass over ± 0.1 inch dynamically at distinct frequencies. After the transient phase of the response was over, the peak roof displacement of the building was recorded during the steady-state response. The range of frequencies and resulting roof displacements are listed in the table below.

Frequency (Hz)	Roof disp. (10^{-3} in)	Frequency (Hz)	Roof disp. (10^{-3} in)
2.00	2.75	2.10	8.25
2.01	3.2	2.11	7.25
2.02	4	2.12	6.25
2.03	4.9	2.13	5
2.04	6.7	2.14	4.5
2.05	9	2.15	4.25
2.06	17.5	2.20	2.75
2.07	15.5		
2.08	12		
2.09	9		

Using the given data, estimate the fundamental period of the structure and the corresponding damping ratio.