

EE-202
Exam I
February 16, 2009

Name: _____
(Please print clearly)

Student ID: _____

CIRCLE YOUR DIVISION

Section 01, 8:30 MWF

Section 02, 12:30 MWF

INSTRUCTIONS

There are 12 multiple choice worth 5 points each and
there is 1 workout problem worth 40 points.

This is a closed book, closed notes exam. No scrap paper or calculators are permitted. A transform table will be handed out separately.

Carefully mark your multiple choice answers on the scantron form. Work on multiple choice problems and marked answers in the test booklet will not be graded.

Nothing is to be on the seat beside you.

When the exam ends, all writing is to stop. This is not negotiable.

No writing while turning in the exam/scantron or risk an F in the exam.

All students are expected to abide by the customary ethical standards of the university, i.e., your answers must reflect only your own knowledge and reasoning ability. As a reminder, at the very minimum, cheating will result in a zero on the exam and possibly an F in the course.

Communicating with any of your classmates, in any language, by any means, for any reason, at any time between the official start of the exam and the official end of the exam is grounds for immediate ejection from the exam site and loss of all credit for this exercise.

MULTIPLE CHOICE.

1. The transfer function of a particular circuit is $H(s) = \frac{ab}{s+a}$, $a > 0$, $b > 0$. The s-domain response of the circuit to $\delta(at)$ is:

- (1) $\frac{ab}{s+a}$ (2) $\frac{b}{s+a^2}$ (3) $\frac{ab}{s+2a}$ (4) $\frac{b}{s+2a}$
 (5) $\frac{ab}{s+a^2}$ (6) $\frac{-ab}{s+a^2}$ (7) $\frac{b}{s+1}$ (8) None of above

Solution 1. $L[\delta(at)] = \frac{1}{a} \Rightarrow \frac{1}{a}H(s) = \frac{b}{s+a}$. ANSWER (8)

2. The inverse Laplace transform of $V(s) = \frac{8s+32}{(s+4)^2+4^2}$ is:

- (1) $4e^{-4t} \sin(4t)u(t)$ (2) $8e^{4t} \sin(4t)u(t)$ (3) $8e^{-4t} \sin(2t)u(t)$
 (4) $8e^{-4t} \sin(4t)u(t)$ (5) $8e^{4t} \cos(4t)u(t)$ (6) $8e^{-4t} \cos(2t)u(t)$
 (7) $8e^{-4t} \cos(4t)u(t)$ (8) None of these

SOLUTION 2. $V(s) = \frac{8s+32}{(s+4)^2+4^2} = 8 \frac{s+4}{(s+4)^2+4^2} \Rightarrow v(t) = 8e^{-4t} \cos(4t)u(t)$ V. ANSWER (7).

3. If $R = 2 \Omega$, $Z_1(s) = s + 2$, and $V_{in}(s) = \frac{4}{s + 4}$, then the Thevenin equivalent voltage, $V_{oc}(s)$, seen at A-B is:

- (1) $\frac{8}{s + 4}$ (2) $\frac{8}{(s + 4)^2}$ (3) $\frac{8}{(s + 2)(s + 4)}$ (4) $\frac{2}{(s + 4)^2}$
 (5) $\frac{4}{(s + 2)(s + 4)}$ (6) $\frac{4}{(s + 4)^2}$ (7) $\frac{2}{(s + 2)(s + 4)}$ (8) None of above

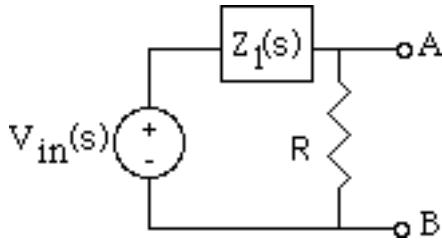

Solution 3. $V_{AB}(s) = V_{oc}(s) = \frac{R}{Z_1(s) + R} V_{in}(s) = \frac{8}{(s + 4)^2}$.

4. In the circuit below, $v_C(0^-) = 0$, $C = 2 \text{ F}$ and $L[v_{in}(t)] = \frac{2}{s^2 + 4}$. Then $i_C(t) =$:

- (1) $2 \sin(2t)u(t)$ (2) $4 \sin(2t)u(t)$ (3) $2 \cos(2t)u(t)$
 (4) $4 \sin(4t)u(t)$ (5) $4 \cos(2t)u(t)$ (6) $4 \cos(4t)u(t)$
 (7) $0.5 \cos(2t)u(t)$ (8) None of these

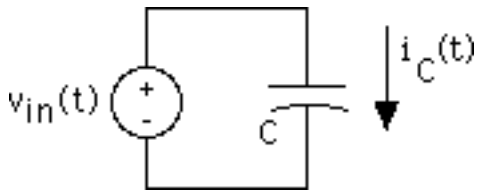

SOLUTION 4. $I_C(s) = CsV_{in}(s) = \frac{2Cs}{s^2 + 4}$. Thus, $i_C(t) = 2C\cos(2t)u(t)$. ANSWER : (5)

5. In the circuit below, $v_C(0^-) = 10$ V, $C = 0.1$ F, $R_1 = 0.4$ Ω , and $R_2 = 0.6$. Then $v_{out}(t) =$ (V):

- (1) $6e^{-0.1t}u(t)$ (2) $4e^{-0.1t}u(t)$ (3) $6e^{-10t}u(t)$ (4) $4u(t)$
 (5) $4e^{-10t}u(t)$ (6) $6u(t)$ (7) $-6e^{-10t}u(t)$ (8) None of above

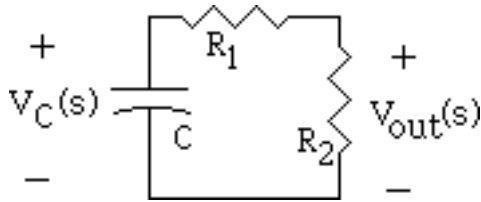

Solution 5. $V_{out}(s) = \frac{R_2}{R_1 + R_2 + \frac{1}{Cs}} \times \frac{10}{s} = \frac{0.6s}{s+10} \times \frac{10}{s} = \frac{6}{s+10}$. ANSWER (3).

6. Suppose $R_2 = 4$ Ω . If $Y_{in}(s) = \frac{1}{0.5s+4} + \frac{s}{0.2+4s}$, then $C =$ (in F):

- (1) 0.5 (2) 0.2 (3) 0.25
 (4) 4 (5) 5 (6) 2
 (7) 0.8 (8) None of these

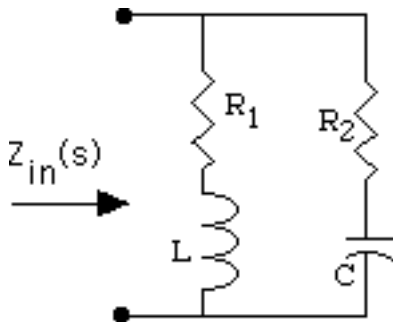

Solution 6. $Y_{in}(s) = \frac{1}{L_1s + R_1} + \frac{s}{\frac{1}{C} + R_2s} = \frac{1}{0.5s + 4} + \frac{s}{0.2 + 4s}$. Thus $C = 5$ F. ANSWER (5).

7. In the circuit below, $R=2\ \Omega$ and $C=1\ \text{F}$. The step response to the circuit below is $v_{out}(t)=$:

- (1) $e^{-2t}u(t)$ (2) $e^{-0.5t}u(t)$ (3) $e^{-0.25t}u(t)$
 (4) $e^{-4t}u(t)$ (5) $e^{0.5t}u(t)$ (6) $e^{2t}u(t)$
 (7) $(1 - e^{-0.5t})u(t)$ (8) None of these

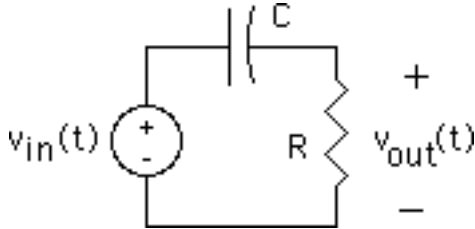

Solution 7. $V_{out}(s) = \frac{R}{R + \frac{1}{Cs}} \times \frac{1}{s} = \frac{s}{s + \frac{1}{RC}} \times \frac{1}{s} = \frac{1}{s + \frac{1}{RC}}$. Thus $v_{out}(t) = e^{-\frac{t}{RC}}u(t)$. ANSWER 2.

8. In the circuit below, $R=1\ \Omega$, $L=2\ \text{H}$, $i_{in}(t)=0$, and $i_L(0^-)=2\ \text{A}$. Then $I_L(s)=$:

- (1) $\frac{-2}{s+0.5}$ (2) $\frac{-2}{s+2}$ (3) $\frac{2}{(s+2)}$
 (4) $\frac{2}{s+0.5}$ (5) $\frac{4}{s+0.5}$ (6) $\frac{-1}{s+0.5}$
 (7) $\frac{1}{s+0.5}$ (8) None of these

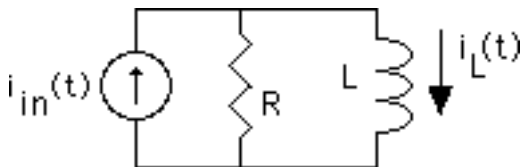

Solution 8. $I_L(s) = \frac{\frac{1}{R}}{\frac{1}{R} + \frac{1}{Ls}} \times \frac{i_L(0^-)}{s} = \frac{1}{1 + \frac{1}{Ls}} \times \frac{i_L(0^-)}{s} = \frac{s}{s + \frac{1}{L}} \times \frac{i_L(0^-)}{s} = \frac{2}{s+0.5}$. ANSWER: (4)

9. In the circuit below, $R = 1 \Omega$, $L = 2 \text{ H}$, $I_{in}(s) = \frac{2}{s(s+0.5)}$, and $i_L(0^-) = 0 \text{ A}$. Then $i_L(t) =$ (in A) :

- (1) $4(e^{-0.5t} - e^{-t})u(t)$ (2) $4te^{-2t}u(t)$ (3) $4te^{-0.5t}u(t)$
 (4) $2te^{-2t}u(t)$ (5) $2te^{-0.5t}u(t)$ (6) $te^{-0.5t}u(t)$
 (7) $\frac{4}{3}(e^{-0.5t} - e^{-2t})u(t)$ (8) None of these

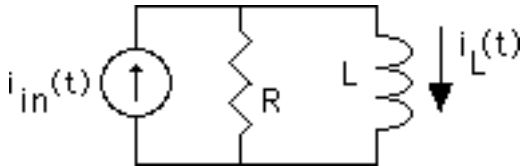

Solution 9. $I_L(s) = \frac{R}{R + Ls} I_{in}(s) = \frac{2}{2s+1} \times \frac{2}{s(s+0.5)} = \frac{2}{s(s+0.5)^2}$. Thus

$i_L(t) = (8 - 8e^{-0.5t} - 4te^{-0.5t})u(t) \text{ A}$. ANSWER: (8)

10. If $C_2 = 1 \text{ F}$, the value of R_1 (in Ω) for which the transfer function for the op amp circuit below is

$H(s) = -\frac{0.5s + 0.25}{s + 10}$ is $R_1 =$ (in Ω):

- (1) 0.1 (2) 2 (3) 0.25 (4) 4
 (5) 0.5 (6) 0.2 (7) 10 (8) None of above

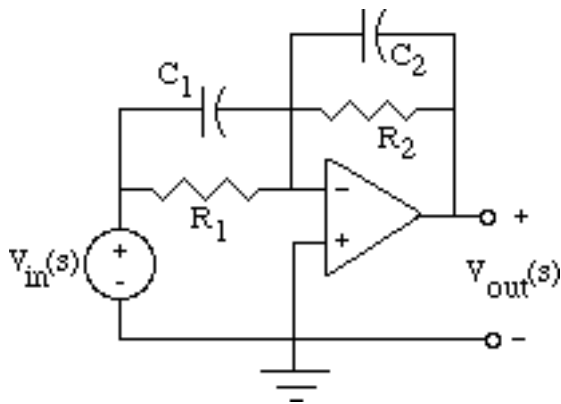

Solution 10: $H(s) = -\frac{Y_{in}(s)}{Y_f(s)} = -\frac{C_1 s + G_1}{C_2 s + G_2} = -\frac{2s + 0.25}{s + 2}$. Thus $R_1 = 4 \Omega$. ANSWER: (4)

11. If $V_{in}(s) = \frac{(b-a)^2}{s+a}$ and $a(s) = \frac{1}{s+b}$ in the circuit below, then $v_{out}(t) = (V)$:

- (1) $(b-a)(e^{-at} - e^{-bt})u(t)$ (2) $(a-b)(e^{-at} - e^{-bt})u(t)$ (3) $(a-b)(e^{-bt} + e^{-at})u(t)$
 (4) $(b-a)(e^{-bt} + e^{-at})u(t)$ (5) $(be^{-bt} - ae^{-at})u(t)$ (6) $(ae^{-bt} - be^{-at})u(t)$
 (7) $(abe^{-bt} - abe^{-at})u(t)$ (8) None of these

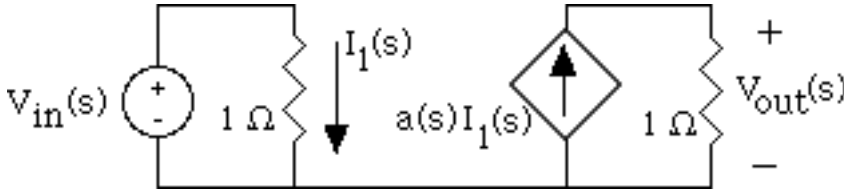

Solution 11. $V_{out}(s) = \alpha(s)V_{in}(s) = \frac{(b-a)^2}{(s+a)(s+b)} = \frac{b-a}{s+a} - \frac{b-a}{s+b}$. Thus

$v_{out}(t) = (b-a)[e^{-at} - e^{-bt}]u(t)$. ANSWER: (1).

12. Suppose $C = \frac{1}{8}$ F, $L = \frac{1}{2}$ H, $v_C(0^-) = 1$ V, $i_L(0^-) = 0$, $v_{in}(t) = \delta(t)$, and the differential equation of a series LC circuit ($i_L(t) = i_C(t)$) driven by a voltage source is

$$L \frac{di_L(t)}{dt} + \frac{1}{C} \int_{-\infty}^t i_L(\tau) d\tau = v_{in}(t) = \delta(t)$$

$I_L(s) = L [i_L(t)] = :$

- (1) $\frac{2s-2}{s^2+16}$ (2) $\frac{2s+2}{s^2+16}$ (3) $\frac{4s-4}{s^2+16}$ (4) $\frac{2s-16}{s^2+16}$
 (5) $\frac{2s+16}{s^2+16}$ (6) $\frac{16s-16}{s^2+16}$ (7) $\frac{4s+4}{s^2+16}$ (8) None of above

Solution 12: $LsI_L(s) - Li_L(0^-) + \frac{I_L(s)}{Cs} + \frac{v_C(0^-)}{s} = \left(Ls + \frac{1}{Cs}\right) I_L(s) + \frac{v_C(0^-)}{s}$

$$\Rightarrow \left(0.5s + \frac{1}{0.125s}\right) I_L(s) = 1 - \frac{1}{s} = \frac{s-1}{s}$$

Thus

$\left(0.5s + \frac{1}{0.125s}\right) I_L(s) = \left(\frac{0.5s^2 + 8}{s}\right) I_L(s) = \frac{s-1}{s}$ implies $I_L(s) = \frac{2s-2}{s^2+16}$. ANSWER (1).

WORKOUT PROBLEM. (40 points) Consider the circuit below. Suppose $R_1 = 2 \Omega$, $R_2 = R_3 = 1 \Omega$, $C_1 = C_2 = 1 \text{ F}$, and $v_{in}(t) = -24u(-t) + 24u(t) + 24u(t-10) \text{ V}$. The switches have been in positions A for a long time and move to positions B at $t = 0$.

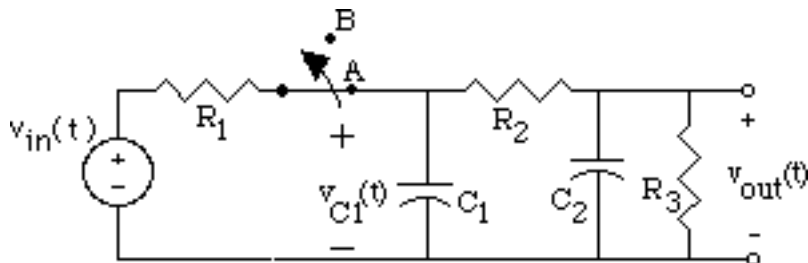

- (a) (5 pts) Find $v_{C1}(0^-)$ and $v_{C2}(0^-)$.
- (b) (5 pts) Draw the s-domain equivalent circuit valid for $t \geq 0$.
- (c) (9 pts) Write a set of nodal equations in terms of $V_{C1}(s)$ and $V_{out}(s)$.
- (d) (13 pts) Solve the set of nodal equations constructed in part (c) and determine $v_{out}(t)$ for $0 \leq t < 10 \text{ s}$.
- (e) (8 pts) Assume that at $t = 10$, the initial conditions on the circuit are $v_{C1}(10^-) = v_{C2}(10^-) = -9 \text{ V}$. Also assume that at $t = 10 \text{ s}$, the switch moves back to position A. Draw the equivalent circuit in the s-domain valid for $t \geq 10$ or $t' \geq 0$, and write out the new nodal equation at $V_{C1}(s)$. Just the correct nodal equation.

Solution Workout

(a)

$$v_{C1}(0^-) = \frac{R_2 + R_3}{R_1 + R_2 + R_3} \times (-24) = \frac{2}{4} \times (-24) = -12 \text{ V.}$$

$$v_{C2}(0^-) = \frac{R_3}{R_1 + R_2 + R_3} \times (-24) = \frac{1}{4} \times (-24) = -6 \text{ V}$$

(b)

(c)

$$\begin{bmatrix} C_1 v_{C1}(0^-) \\ C_2 v_{C2}(0^-) \end{bmatrix} = \begin{bmatrix} C_1 s + G_2 & -G_2 \\ -G_2 & C_2 s + G_2 + G_3 \end{bmatrix} \begin{bmatrix} V_{C1}(s) \\ V_{out}(s) \end{bmatrix} = \begin{bmatrix} s+1 & -1 \\ -1 & s+2 \end{bmatrix} \begin{bmatrix} V_{C1}(s) \\ V_{out}(s) \end{bmatrix}$$

(d)

$$\begin{bmatrix} V_{C1}(s) \\ V_{out}(s) \end{bmatrix} = \begin{bmatrix} s+1 & -1 \\ -1 & s+2 \end{bmatrix}^{-1} \begin{bmatrix} C_1 v_{C1}(0^-) \\ C_2 v_{C2}(0^-) \end{bmatrix} = \frac{1}{s^2 + 3s + 1} \begin{bmatrix} s+2 & 1 \\ 1 & s+1 \end{bmatrix} \begin{bmatrix} -12 \\ -6 \end{bmatrix}$$

Thus

$$\begin{bmatrix} V_{C1}(s) \\ V_{out}(s) \end{bmatrix} = \frac{-6}{s^2 + 3s + 1} \begin{bmatrix} 2s+5 \\ s+3 \end{bmatrix} \text{ (full credit for this part for this answer)}$$

$$\text{implies } \begin{bmatrix} v_{C1}(t) \\ v_{out}(t) \end{bmatrix} = \begin{bmatrix} (-0.6334e^{-2.618t} - 11.366e^{-0.3820t}) \\ (-1.0249e^{-2.618t} - 7.0249e^{-0.3820t}) \end{bmatrix} u(t)$$

(e) Answer is just the top equation, not the bottom.

$$\begin{bmatrix} C_1 v_{C1}(0^-) + G_1 V_{in}(s) \\ C_2 v_{C2}(0^-) \end{bmatrix} = \begin{bmatrix} -9 + \frac{24}{s} \\ -9 \end{bmatrix} = \begin{bmatrix} C_1 s + G_1 + G_2 & -G_2 \\ -G_2 & C_2 s + G_2 + G_3 \end{bmatrix} \begin{bmatrix} V_{C1}(s) \\ V_{C2}(s) \end{bmatrix} = \begin{bmatrix} s+1.5 & -1 \\ -1 & s+2 \end{bmatrix} \begin{bmatrix} V_{C1}(s) \\ V_{C2}(s) \end{bmatrix}$$

Table 13.1 LAPLACE TRANSFORM PAIRS

Item Number	$f(t)$	$\mathcal{L}[f(t)] = F(s)$
1	$K\delta(t)$	K
2	$Ku(t)$ or K	$\frac{K}{s}$
3	t	$\frac{1}{s^2}$
4	$t^n u(t)$	$\frac{n!}{s^{n+1}}$
5	$e^{-at}u(t)$	$\frac{1}{s+a}$
6	$te^{-at}u(t)$	$\frac{1}{(s+a)^2}$
7	$t^n e^{-at}u(t)$	$\frac{n!}{(s+a)^{n+1}}$
8	$\sin(\omega t)u(t)$	$\frac{\omega}{s^2 + \omega^2}$
9	$\cos(\omega t)u(t)$	$\frac{s}{s^2 + \omega^2}$
10	$e^{-at}\sin(\omega t)u(t)$	$\frac{\omega}{(s+a)^2 + \omega^2}$
11	$e^{-at}\cos(\omega t)u(t)$	$\frac{(s+a)}{(s+a)^2 + \omega^2}$

12	$t\sin(\omega t)u(t)$	$\frac{2\omega s}{(s^2 + \omega^2)^2}$
13	$t\cos(\omega t)u(t)$	$\frac{s^2 - \omega^2}{(s^2 + \omega^2)^2}$
14	$\sin(\omega t + \phi)u(t)$	$\frac{s\sin(\phi) + \omega \cos(\phi)}{s^2 + \omega^2}$
15	$\cos(\omega t + \phi)u(t)$	$\frac{s\cos(\phi) - \omega \sin(\phi)}{s^2 + \omega^2}$
16	$e^{-at}[\sin(\omega t) - \omega t\cos(\omega t)]u(t)$	$\frac{2\omega^3}{[(s+a)^2 + \omega^2]^2}$
17	$te^{-at}\sin(\omega t)u(t)$	$2\omega \frac{s+a}{[(s+a)^2 + \omega^2]^2}$
18	$e^{-at}\left[C_1 \cos(\omega t) + \left(\frac{C_2 - C_1 a}{\omega}\right) \sin(\omega t)\right]u(t)$	$\frac{C_1 s + C_2}{(s+a)^2 + \omega^2}$
19	$2\sqrt{A^2 + B^2} e^{-at} \cos\left(\omega t - \tan^{-1}\left(\frac{B}{A}\right)\right)$	$\frac{A + jB}{s+a+j\omega} + \frac{A - jB}{s+a-j\omega}$
20	$2\sqrt{A^2 + B^2} t e^{-at} \cos\left(\omega t - \tan^{-1}\left(\frac{B}{A}\right)\right)$	$\frac{A + jB}{(s+a+j\omega)^2} + \frac{A - jB}{(s+a-j\omega)^2}$

Table 13.2 LAPLACE TRANSFORM PROPERTIES

Property	Transform Pair
Linearity	$\mathcal{L}[a_1 f_1(t) + a_2 f_2(t)] = a_1 F_1(s) + a_2 F_2(s)$
Time Shift	$\mathcal{L}[f(t-T)u(t-T)] = e^{-sT}F(s), T > 0$
Multiplication by t	$\mathcal{L}[t f(t)u(t)] = -\frac{d}{ds} F(s)$
Multiplication by t^n	$\mathcal{L}[t^n f(t)] = (-1)^n \frac{d^n F(s)}{ds^n}$
Frequency Shift	$\mathcal{L}[e^{-at}f(t)] = F(s+a)$
Time Differentiation	$\mathcal{L}\left[\frac{d}{dt} f(t)\right] = sF(s) - f(0^-)$

Second-Order Differentiation	$\mathcal{L}\left[\frac{d^2 f(t)}{dt^2}\right] = s^2 F(s) - sf(0^-) - f^{(1)}(0^-)$
<i>n</i> th-Order Differentiation	$\mathcal{L}\left[\frac{d^n f(t)}{dt^n}\right] = s^n F(s) - s^{n-1} f(0^-) - s^{n-2} f^{(1)}(0^-) - \dots - f^{(n-1)}(0^-)$
Time Integration	<p>(i) $\mathcal{L}\left[\int_{-\infty}^t f(q) dq\right] = \frac{F(s)}{s} + \frac{\int_{-\infty}^{0^-} f(q) dq}{s}$</p> <p>(ii) $\mathcal{L}\left[\int_{0^-}^t f(q) dq\right] = \frac{F(s)}{s}$</p>
Time/Frequency Scaling	$\mathcal{L}[f(at)] = \frac{1}{a} F\left(\frac{s}{a}\right)$