

Development of D.C. and Hybrid- $\pi$  models for a 2N3704 Bipolar Transistor.  
(Dry lab of ECE 208 Experiments #9A and #11)

This exercise will use the PSpice model MPS3704 (which is actually a 2N3704 in a different package). The model parameters from Cadence PSpice are given below.

```
.model MPS3704 NPN(Is=26.03f Xti=3 Eg=1.11 Vaf=90.7 Bf=736.1K Ne=1.232
+ Ise=26.03f Ikf=.1983 Xtb=1.5 Br=1.024 Nc=2 Isc=0 Ikr=0 Rc=.5
+ Cjc=11.01p Mjc=.3763 Vjc=.75 Fc=.5 Cje=24.07p Mje=.3641 Vje=.75
+ Tr=233.8n Tf=1.03n Itf=0 Vtf=0 Xtf=0 Rb=10)
```

- To verify that your transistor model is correct, plot the input characteristics @  $V_{CE} = 2\text{ V}$  and the output characteristics for  $I_B = 20, 40, 60, 80,$  and  $100\ \mu\text{A}$  for  $0 \leq V_{CE} \leq 10\text{ V}$  to obtain the plots shown below.

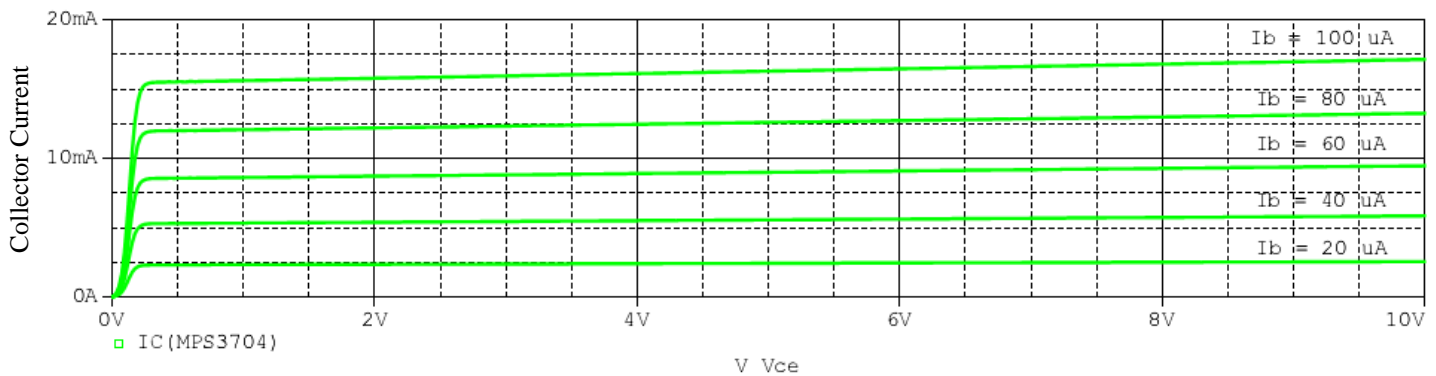
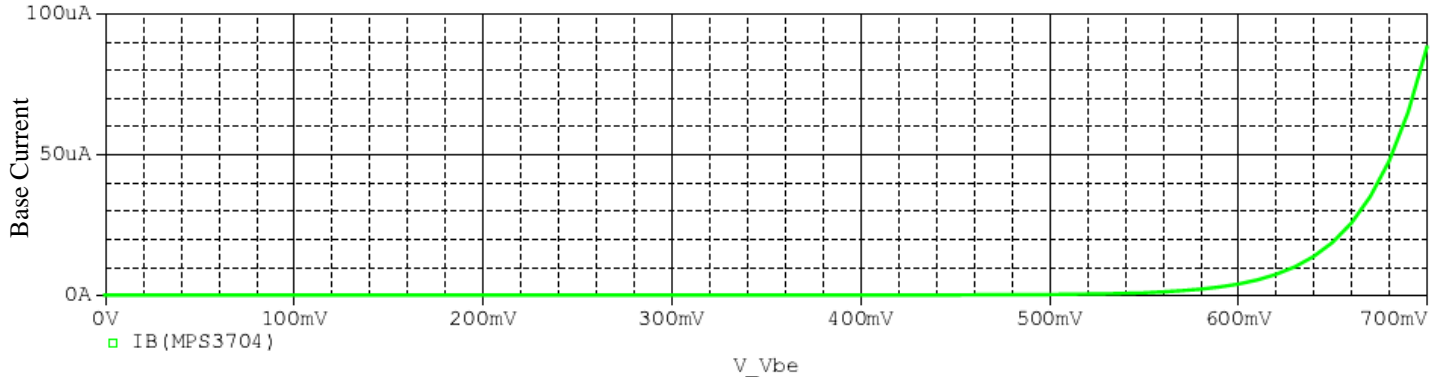

- The model for the forward biased Base-Emitter junction consists of a series D.C. voltage source,  $V_0$ , and series resistor,  $R_{BB}$  connected between the Base and Emitter terminals. Using your plot of the transistor input characteristics determine and list appropriate values for both  $V_0$  and  $R_{BB}$  at operating points characterized by  $I_B = 20\ \mu\text{A}$  and  $50\ \mu\text{A}$ .

$I_B$	$V_{BE}$	$R_{BB}$	$V_0$
20 $\mu\text{A}$	.652 V	1.60 k $\Omega$	.620 V
50 $\mu\text{A}$	.681 V	.645 k $\Omega$	.649 V

NOTE: Remember that the d( ) operator can be used to find the derivative of a PSpice curve. Additional copies of the tables appear on the last page for use in your report.

3. Plot the V-I characteristics (using “Add Trace ...” in the plot window) of your models on the input characteristics as shown below.

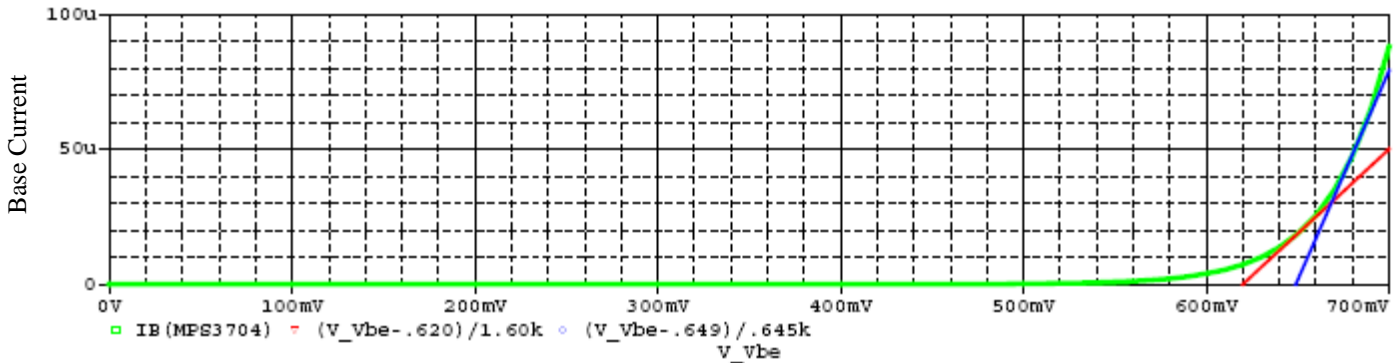

4. The output characteristics are modeled by the parallel combination of an independent current source,  $I_{CE0}$ , a dependent current source,  $\beta_{dc} I_B$ , and a resistor,  $R_d$ . In this case, the independent current source,  $I_{CE0}$ , can be considered unimportant. Determine and list values for the control of the independent source,  $\beta_{dc}$ , and the parallel resistor,  $R_d$ .

$I_B$	$\beta_{dc}$	$R_d$
20 $\mu A$	113	39.8 $k\Omega$
40 $\mu A$	130	17.2 $k\Omega$
60 $\mu A$	141	10.6 $k\Omega$
80 $\mu A$	149	7.57 $k\Omega$
100 $\mu A$	154	5.84 $k\Omega$

5. Using the equation,  $I_C = \beta_{dc} I_B + V_{CE} / R_d$ , plot the characteristics of the models you have created (using “Add Trace ...” in the plot window) on the output characteristics of the transistor as shown below.

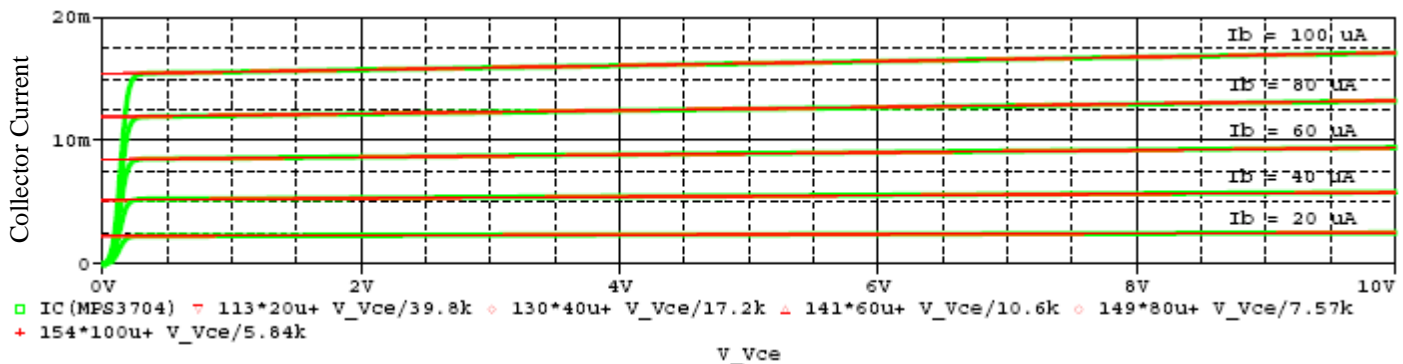

6. On a second plot, extend the sweep to negative voltages and show that your model characteristics converge to a single point; then using the cursor, mark that point, the Early Voltage, ( $-V_A$ ).

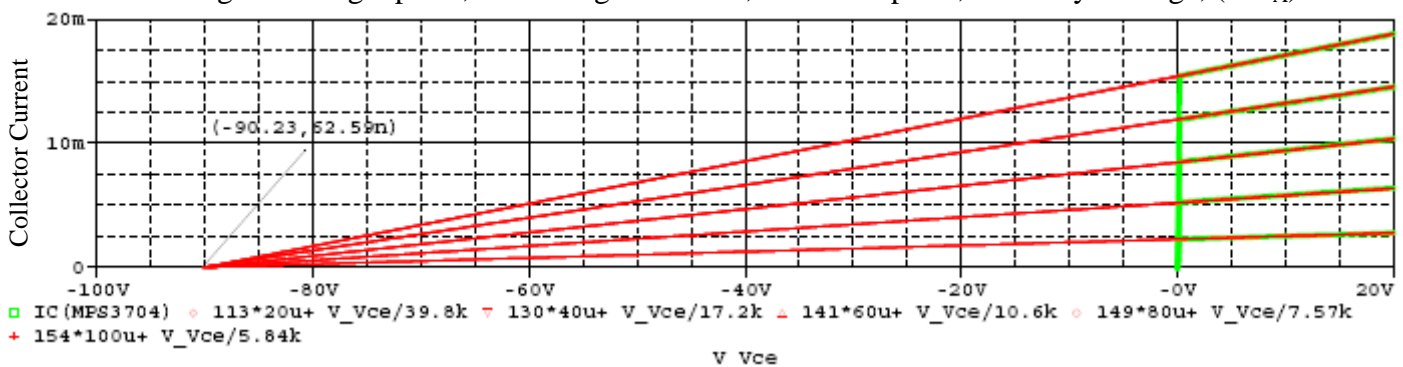

## Determination of the Hybrid- $\pi$ model parameters

In the ECE 208 Experiment #11, you will build the following circuit (using a 2N3704 on place of the MPS3704):

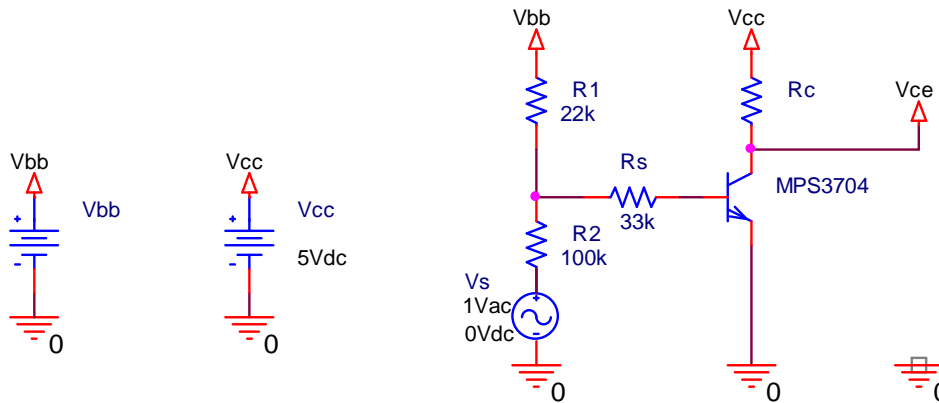

In the lab, you will insert different values of  $R_C$  and adjust  $V_{BB}$  to make  $V_{CE} = 2$  V before each set of measurements to determine the Hybrid- $\pi$  model parameters. You could perform this same procedure in PSpice by inserting a particular value of  $R_C$  and sweeping  $V_{BB}$  to determine the value of  $V_{BB}$  that makes  $V_{CE}$  exactly 2 V. However, PSpice has a variety of tools that we can use to make this process much simpler.

For example, we can build the circuit so that it will automatically bias itself at  $V_{CE} = 2$  V.

Consider the circuit below, in which the D.C. source  $V_{BB}$  has been replaced by a voltage-controlled voltage source, element E.

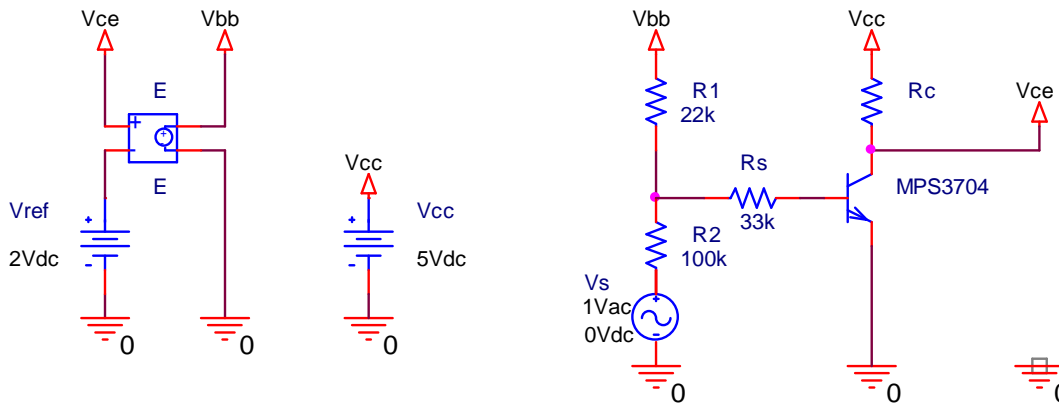

The voltage-controlled voltage source (element E) has a control which is  $V_{CE} - 2$  V and an output voltage  $V_{BB} = \text{gain} * (V_{CE} - 2$  V). If  $V_{CE}$  is greater than 2 V, the voltage-controlled voltage source will produce a positive voltage which increases  $I_B$ , and consequently  $I_C$ , which increases the voltage drop across  $R_C$  thereby reducing  $V_{CE}$ . The bigger we make the gain of element E, the closer the value of  $V_{CE}$  will be to 2 V. Let's make the gain at least 100k and then  $V_{CE}$  should be within a few microvolts of the desired value. Try it out by setting  $R_C = 6$  k $\Omega$  and check the bias point,  $V_{CE}$ .

Now if we could automatically change the values of  $R_C$ , we could get all of our data in one simulation.

In the following circuit a global parameter R has been introduced which will be used to set the value of resistor  $R_C$ .

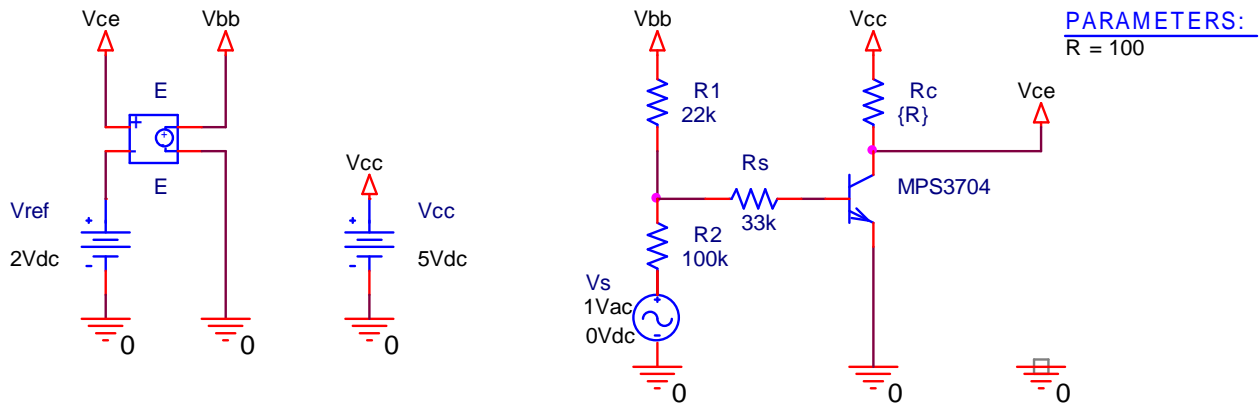

We can now do a D.C. sweep of the global parameter R using the given list of resistor values to measure the desired quantities.

7. Make the D.C. measurements necessary to complete the table below.

Nominal D.C. Values			D.C. Measurements		
$I_C$	$R_C$	$V_{CE}$	$V_{BB}$	$V_{BE}$	$I_B$
0.5 mA	6000 $\Omega$	2.0 V	1.104 V	612 mV	5.73 $\mu A$
1.0 mA	3000 $\Omega$	2.0 V	1.396 V	630 mV	10.08 $\mu A$
2.0 mA	1500 $\Omega$	2.0 V	1.896 V	648 mV	17.75 $\mu A$
5.0 mA	600 $\Omega$	2.0 V	3.18 V	673mV	37.8 $\mu A$
10.0 mA	300 $\Omega$	2.0 V	5.06 V	692mV	67.7 $\mu A$
30.0 mA	100 $\Omega$	2.0 V	11.96 V	723 mV	177.9 $\mu A$

The data in the table above can be used to compute approximate values of the Hybrid- $\pi$  model parameters by using the finite difference calculations discussed in ECE 208 Lab Experiment #11. In fact, we will use these values to check our Hybrid- $\pi$  model parameters as the last step of this exercise.

To directly determine the Hybrid- $\pi$  model parameters we will make A.C. terminal measurements. Before we begin, we need to consider what effect the automatic bias elements we added will have on our measurements. We introduced a voltage-controlled voltage source and feedback. Even though the feedback path and amplifier were only intended to provide D.C. voltages to set the bias point, they will also provide a feedback path for A.C. signals.

To avoid feedback of the A.C. signals, we could simply return to the original circuit and set  $V_{BB}$  with a D.C. voltage source to the values in the table above and run a simulation for each value of  $R_C$ .

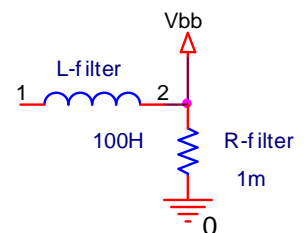

Not wanting to be accused of taking the easy way out, lets break the A.C. signal feedback path and continue with our auto bias circuit. We need an element that has zero resistance at D.C. but a large impedance for A.C. signals. Anything come to mind? Try adding the filter shown to the output of the voltage-controlled voltage source (element E).

There certainly are fancier filters that can be made with more realistic component values; however, we need to be careful. We are using an amplifier with a gain greater than  $10^5$  followed by an attenuator with an attenuation ratio greater than  $10^{-8}$ . The precision of the calculations is now becoming very important. Our answer (signal) could be lost in round-off errors. On the Options tab in Simulation Settings, we have the opportunity to control the accuracy of the simulation. The simple filter shown will work using the default settings, some other filters will not. Remember that simulation programs in general and PSpice in particular will not tell you when the simulation results are nonsense – It is your responsibility to check.

8. Using an A.C. sweep in the range of 1 kHz to 10 kHz together with the global parameter sweep (or setting  $V_{BB}$  and  $R_C$  if you are not using the auto bias circuit) determine the values need to complete the table below.

Nominal D.C. Values			A.C. Measurements			
$I_C$	$R_C$	$V_{CE}$	$v_{be}$	$i_b$	$V_{ce}$	$i_c$
0.5 mA	6000 $\Omega$	2.0 V	17.75 mV	3.19 $\mu$ A	1985 mV	331 $\mu$ A
1.0 mA	3000 $\Omega$	2.0 V	10.55 mV	3.33 $\mu$ A	1175 mV	392 $\mu$ A
2.0 mA	1500 $\Omega$	2.0 V	6.16 mV	3.41 $\mu$ A	681 mV	454 $\mu$ A
5.0 mA	600 $\Omega$	2.0 V	2.96 mV	3.48 $\mu$ A	321 mV	535 $\mu$ A
10.0 mA	300 $\Omega$	2.0 V	1.682 mV	3.50 $\mu$ A	176.6 mV	589 $\mu$ A
30.0 mA	100 $\Omega$	2.0 V	.668 mV	3.52 $\mu$ A	62.7 mV	627 $\mu$ A

All of the measurements for ECE 208 Lab Experiment #11 are now complete. At this point you would calculate the Hybrid- $\pi$  model parameters. However, we have assumed to this point that the output resistance,  $r_d$ , is infinite. Let's check to see if that is true.

If we simply try to measure the output impedance to determine  $r_d$ , we would find that  $r_d$  is in parallel with  $R_C$  and that it is very difficult to determine the value of a large resistor that is in parallel with a relatively small resistor ( $R_C$ ). We can overcome this limitation by making  $R_C$  much larger. The table below shows the new values of  $R_C$ . To maintain the same operating point, we need to increase  $V_{CC}$  a bit, to 30 kV (30.002 kV for the perfectionist). *Do not try using a 30 kV source at home.*

9. Remove the A.C. source from its present location in the bias network and A.C. couple it to the collector. The output resistance can now be measured as the ratio of the A.C. source voltage to the source current. You will probably see the effect of the capacitors in the transistor model as well as the filter in the auto bias circuit when you do the A.C. sweep. Try extending the sweep from 100 Hz to 10 kHz and pick the peak values of  $r_d$  to report in the table below.

Nominal D.C. Values			A.C.
$I_C$	$R_C$	$V_{CE}$	$r_d$
0.5 mA	60 M $\Omega$	2.0 V	184 k $\Omega$
1.0 mA	30 M $\Omega$	2.0 V	91.8 k $\Omega$
2.0 mA	15 M $\Omega$	2.0 V	45.9 k $\Omega$
5.0 mA	6 M $\Omega$	2.0 V	18.4 k $\Omega$
10.0 mA	3 M $\Omega$	2.0 V	9.17 k $\Omega$
30.0 mA	1 M $\Omega$	2.0 V	3.06 k $\Omega$

Finish by producing the plots listed below using the data you have collected in the tables above as specified in the ECE 208 Lab Manual for Experiment #11. These are **not** PSpice plots. You can use Excel, Matlab, etc. to make these plots.

10. Plot  $\beta_{dc}$  and  $\beta_0 = \frac{i_c - (v_{ce}/r_d)}{i_b}$  vs.  $I_C$  (on the same graph) using linear scales.

11. Plot  $r_\pi = v_{be}/i_b$  and  $\approx r_\pi \approx \frac{\Delta V_{BE}}{\Delta I_{BE}}$  vs.  $I_C$  (on the same graph) using a log-log scale

12. Plot  $R_d$  and  $r_d$  vs.  $I_C$  (on the same graph) using log-log scales.

13. Plot  $g_m = \beta_0/r_\pi$  vs.  $I_C$  using linear scales.

### Minimum report requirements:

- 1) Completed cover page showing simulation measurements (cover page is provided below).
- 2) One input characteristic plot (with model characteristics) from Part 3, one output plot (with model characteristics) from Part 5, and one plot from Part 6 showing models converging to  $-V_A$ . All three plots can be on the same page – be sure that the traces are clearly visible and that you retain the trace definitions that the Probe program generates and displays below the plots.
- 3) A PSpice schematic of the complete circuit used to make the measurements in Part 7. (You may submit a hand drawn schematic if and only if (iff) you are using the nanohub.)
- 4) The complete Spice output file corresponding to the schematic used for Item 3 above (exercise Part 7). (You may remove page breaks, blank lines, and reduce font size to no smaller than 8 points if you wish to conserve paper; however, do not alter any text in the output file)
- 5) Write (or print) the node designations (the automatically generated node numbers) appearing in the output file (Item 4) on the schematic (Item 3).
- 6) Provide plots (not PSpice plots) of measurement results reported in the tables from Parts 10 through 13

**NOTE:** You will receive **no** credit if Items 3, 4, and 5 are not submitted **or there is evidence that the work is not your own**. The use of the auto bias circuit is optional in all Parts of this exercise.

Although you are encouraged to work with your classmates, each student is required to create their own simulation and produce their plots and other results from their own unique simulations. Potential sanctions are provided on the course website.

**ECE 255  
Fall 2009****ELECTRONIC ANALYSIS AND DESIGN**  
PSpice Design 1– Measurement Results

$I_B$	$V_{BE}$	$R_{BB}$	$V_0$
20 $\mu\text{A}$	.652 V	1.60 k $\Omega$	.620 V
50 $\mu\text{A}$	.681 V	.645 k $\Omega$	.649 V

$I_B$	$\beta_{dc}$	$R_d$
20 $\mu\text{A}$	113	39.8 k $\Omega$
40 $\mu\text{A}$	130	17.2 k $\Omega$
60 $\mu\text{A}$	141	10.6 k $\Omega$
80 $\mu\text{A}$	149	7.57 k $\Omega$
100 $\mu\text{A}$	154	5.84 k $\Omega$

<p>Early Voltage</p> $V_A = \underline{\quad \approx 90 \text{ V} \quad}$
---------------------------------------------------------------------------

Nominal D.C. Values			D.C. Measurements		
$I_C$	$R_C$	$V_{CE}$	$V_{BB}$	$V_{BE}$	$I_B$
0.5 mA	6000 $\Omega$	2.0 V	1.104 V	612 mV	5.73 $\mu\text{A}$
1.0 mA	3000 $\Omega$	2.0 V	1.396 V	630 mV	10.08 $\mu\text{A}$
2.0 mA	1500 $\Omega$	2.0 V	1.896 V	648 mV	17.75 $\mu\text{A}$
5.0 mA	600 $\Omega$	2.0 V	3.18 V	673mV	37.8 $\mu\text{A}$
10.0 mA	300 $\Omega$	2.0 V	5.06 V	692mV	67.7 $\mu\text{A}$
30.0 mA	100 $\Omega$	2.0 V	11.96 V	723 mV	177.9 $\mu\text{A}$

Nominal D.C. Values			A.C. Measurements				
$I_C$	$R_C$	$V_{CE}$	$v_{be}$	$i_b$	$v_{ce}$	$i_c$	$r_d^*$
0.5 mA	6000 $\Omega$	2.0 V	17.75 mV	3.19 $\mu\text{A}$	1985 mV	331 $\mu\text{A}$	184 k $\Omega$
1.0 mA	3000 $\Omega$	2.0 V	10.55 mV	3.33 $\mu\text{A}$	1175 mV	392 $\mu\text{A}$	91.8 k $\Omega$
2.0 mA	1500 $\Omega$	2.0 V	6.16 mV	3.41 $\mu\text{A}$	681 mV	454 $\mu\text{A}$	45.9 k $\Omega$
5.0 mA	600 $\Omega$	2.0 V	2.96 mV	3.48 $\mu\text{A}$	321 mV	535 $\mu\text{A}$	18.4 k $\Omega$
10.0 mA	300 $\Omega$	2.0 V	1.682 mV	3.50 $\mu\text{A}$	176.6 mV	589 $\mu\text{A}$	9.17 k $\Omega$
30.0 mA	100 $\Omega$	2.0 V	.668 mV	3.52 $\mu\text{A}$	62.7 mV	627 $\mu\text{A}$	3.06 k $\Omega$

\*  $r_d$  was determined using values of  $R_C$  that are 10,000 times larger than the values shown on the left.

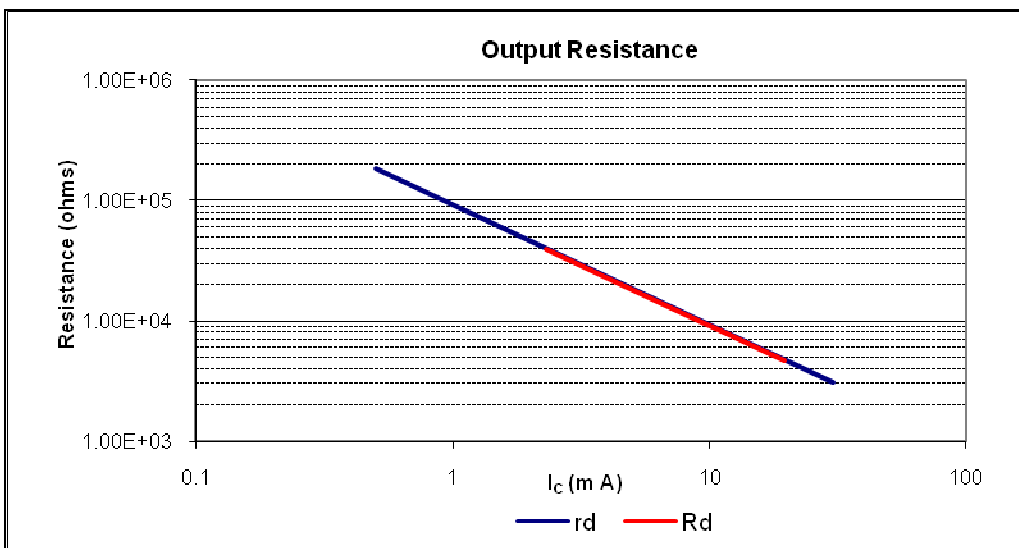
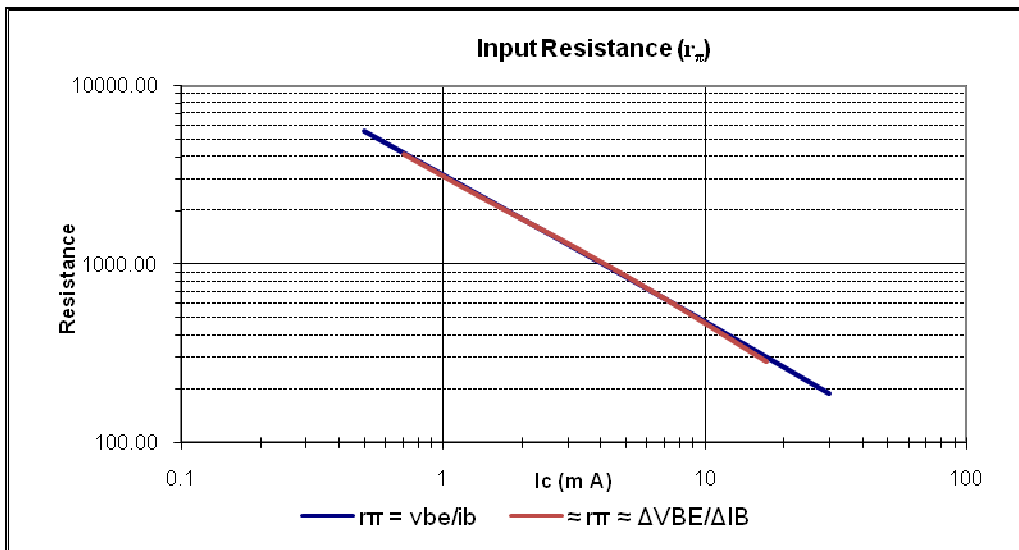
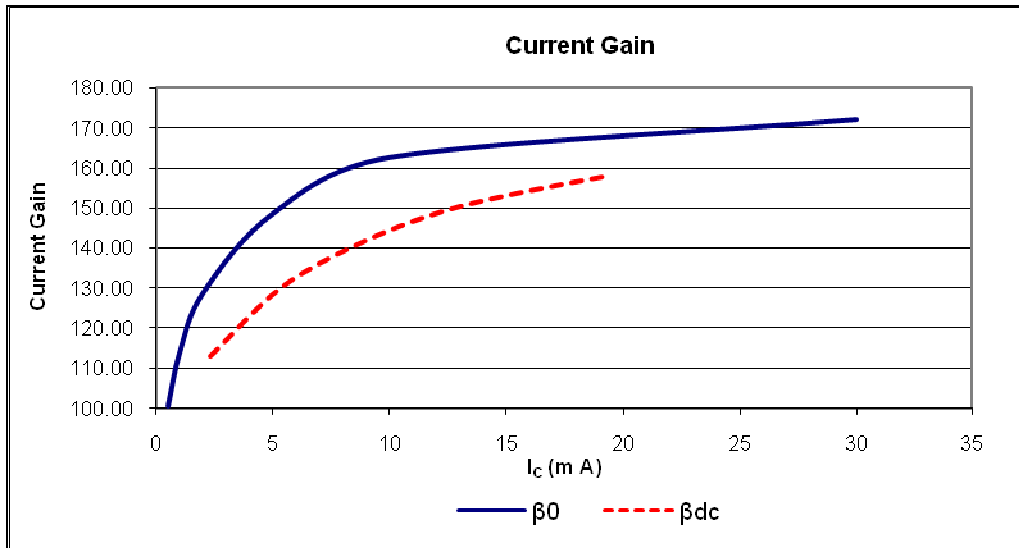

### Transconductance

