

# EE648 (CC761-M) DSP II

## Session 5 (hive: 1/26/99)

Outline:

- Adaptive Noise Cancellation
- Adaptive Suppression of Narrowband Interference in a Wideband Signal
- Sect. 12.1 of 1<sup>st</sup> Ed. of P+M

- Application: Adaptive Noise Cancellation
- specifically: car phone embedded in steering wheel
- speech masked by "car noise"
- approach: place "mike" at point in car to pick up "car noise" only
- form an estimate of noise contaminating speech and subtract it off

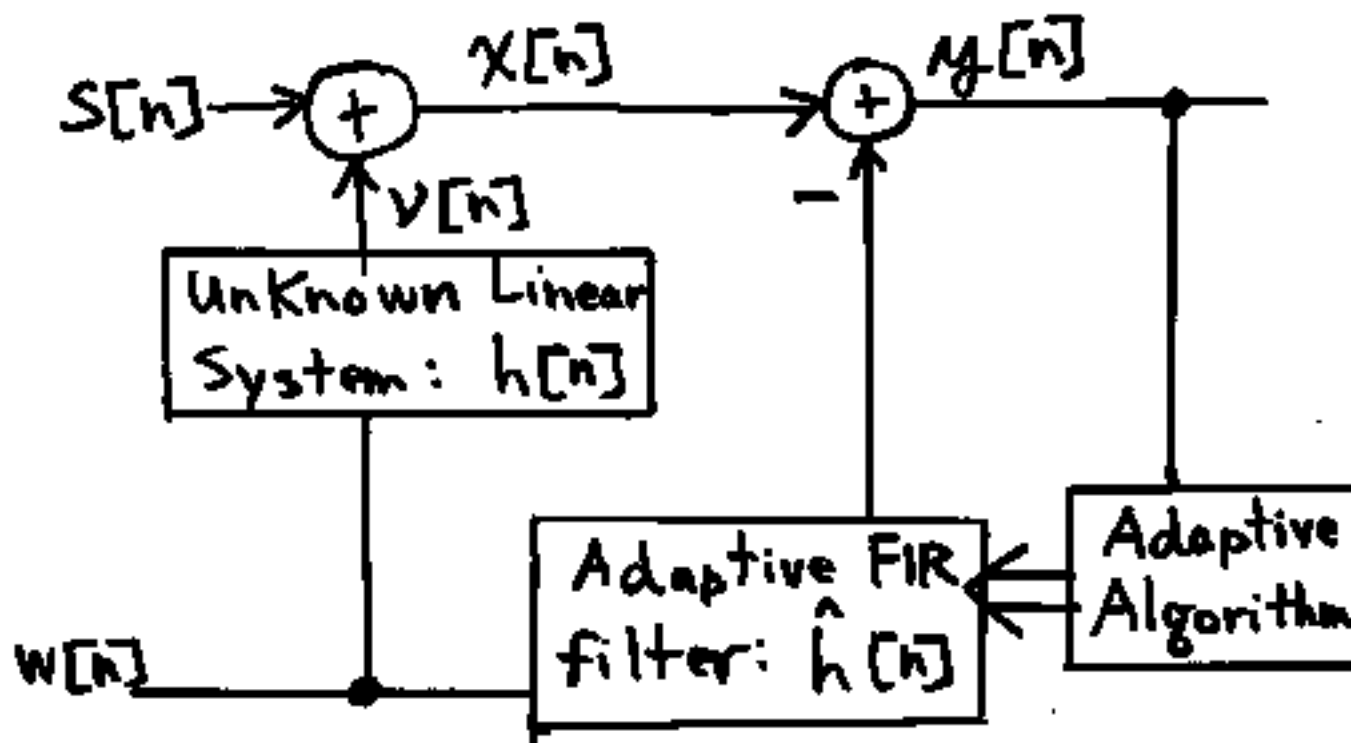

- $s[n]$ : Speech only (unobservable)
- $w[n]$ : noise-only observed at "remote" sensor ("mike")
- $v[n]$ : filtered version of  $w[n]$  that corrupts desired speech (unobservable)  

$$v[n] = w[n] * h[n]$$
- $x[n] = s[n] + v[n] \Rightarrow$  picked up by "mike" in steering wheel

• Choose  $\hat{h}[n]$  to minimize

$$E\{y^2[n]\} = E\left\{\left[x[n] - \sum_{k=0}^{M-1} \hat{h}[n] w[n-k]\right]^2\right\}$$

$$= E\left\{\left[x[n] - \hat{\underline{h}}_n^T \underline{w}[n]\right]^2\right\}$$

• where:

$$\hat{\underline{h}}_n = [\hat{h}[0], \hat{h}[1], \dots, \hat{h}[M-1]]^T$$
$$\underline{w}[n] = [w[n], w[n-1], \dots, w[n-(M-1)]]^T$$

• Show:  $\hat{\underline{h}}_M^{\text{opt}} = \underline{h}$

• Recall:  $\begin{aligned} x[n] &= s[n] + v[n] \\ &= s[n] + w[n] * h[n] \\ &= s[n] + \underline{h}^T \underline{w}[n] \end{aligned}$

• Note: Assume  $s[n]$  and  $w[n]$  are independent random processes and  $E\{w[n]\} = 0$

$$E\left\{\left[s[n] + \underline{h}^T \underline{w}[n] - \hat{\underline{h}}_M^T \underline{w}[n]\right]^2\right\}$$

$$\begin{aligned}
&= E\left\{ \left[ s[n] + (\underline{b} - \hat{\underline{b}}_M)^T \underline{w}[n] \right]^2 \right\} \\
&= E\{s^2[n]\} + 2(\underline{b} - \hat{\underline{b}}_M)^T E\{s[n]\underline{w}[n]\} \\
&\quad + (\underline{b} - \hat{\underline{b}}_M)^T E\{\underline{w}[n]\underline{w}^T[n]\} (\underline{b} - \hat{\underline{b}}_M) \rightarrow 0 \\
&= E\{s^2[n]\} + (\underline{b} - \hat{\underline{b}}_M)^T \underline{R}_{ww} (\underline{b} - \hat{\underline{b}}_M) \\
&\cdot \text{thus: } \hat{\underline{b}}_M^{\text{opt}} = \underline{b} \text{ since } \underline{R}_{ww} = \\
&E\{\underline{w}[n]\underline{w}^T[n]\} \text{ is positive definite}
\end{aligned}$$

- in implementing either LMS or RLS;
- $x[n]$ : plays role of desired signal  $d[n]$
- $y[n]$ : plays role of error signal  $e[n]$
- See summary of LMS/RLS for Adaptive Noise Cancellation delineated in Hmwk. 1 write-up

• Summary of LMS/RLS for Adaptive Noise Cancellation

• for RLS (with  $w = \gamma$ )

$$y[n, n-1] = x[n] - \underline{h}_M^T[n-1] \underline{w}[n]$$

$$\underline{f}[n] = \underline{R}_{ww}^{-1}[n-1] \underline{w}[n]$$

$$\mu[n] = \gamma + \underline{w}^T[n] \underline{f}[n]$$

$$\underline{K}_M[n] = \underline{f}[n] / \mu[n]$$

$$\underline{h}_M[n] = \underline{h}_M[n-1] + y[n, n-1] \underline{K}_M[n]$$

$$\underline{R}_{ww}^{-1}[n] = \frac{1}{\sigma^2} \left\{ \underline{R}_{ww}^{-1}[n-1] + \underline{K}_M[n] \underline{f}^T[n] \right\}$$

Go to Step 1

- for LMS:  $y[n] = x[n] - \underline{h}_M^T[n] \underline{w}[n]$   
 $\underline{h}_M[n+1] = \underline{h}_M[n] + \mu y[n] \underline{w}[n]$

- See demo NoiseCancel.m and WordCancel.m at course web site

• Suppression of Narrowband

Interference in a wideband

Signal  $x[n] = s[n] + i[n]$

information (wideband)  $\underbrace{s[n]}$   $\underbrace{i[n]}$  interference (narrowband)

• Assumption 1:  $s[n]$  and  $i[n]$  are independent random processes

- $s[n]$ : "wideband" signal
- power spectral density,  $S_{ss}(\omega)$ , is generally non-negligible over a wide range of frequencies
- as a result, the autocorrelation  $r_{ss}[m]$  is highly localized near  $m=0$
- Extreme case: white noise

$$r_{ss}[m] = \sigma_w^2 \delta[m] \xleftrightarrow{\text{DTFT}} S_{ss}(\omega) = \sigma_w^2 \text{ for all } \omega$$

- assumption:  $r_{ss}[m] \approx 0$  for  $|m| \geq D$   
where  $D$  is not too large
- In contrast:  
 $i[n]$ : "narrowband" signal
- $S_{ii}(\omega)$  is highly concentrated  
in frequency:  $S_{ii}(\omega) \approx 0$  except  
over  $\omega_0 - \Delta\omega < \omega < \omega_0 + \Delta\omega$   
where  $\Delta\omega$  is small
- as a result:  $r_{ii}[m]$  is generally  
nonzero for a large range of  $m$

• Extreme case:  $i[n] = e^{j(\omega_0 n + \theta)}$   
 $\neq n$

$$r_{ii}[m] = e^{j\omega_0 m} \xleftrightarrow{\text{DTFT}} \int_{\omega} S_{ii}(\omega) = 2\pi\delta(\omega - \omega_0)$$

for  $-\pi < \omega < \pi$

• in particular:  $r_{ii}[m] \neq 0$  for  $D \leq m \leq D+M$

• specifically, assumption is  $i[n+D]$  is highly correlated with  $i[n], i[n-1], \dots, i[n-(M-1)]$

• whereas  $s[n+D]$  is uncorrelated with  $s[n], s[n-1], \dots, s[n-(M-1)]$

• criterion for suppressing  $i[n]$ :

$$\text{Min}_{h[n]} E \left\{ \left[ x[n+D] - \sum_{k=0}^{M-1} h[k] x[n-k] \right]^2 \right\}$$

• thus:  $x[n+D]$  plays role of  
"desired" signal

$$\text{Min}_{h[n]} E \left\{ \left[ x[n+D] - \underline{h}_M^T \underline{x}[n] \right]^2 \right\}$$

Define:  $\tilde{h}[n] = \begin{cases} 1, & n=0 \\ 0, & n=1, \dots, D-1 \\ -h[n-D], & n=D, \dots, D+M-1 \end{cases}$

• the objective may be expressed as

$$\text{Min}_{\tilde{h}[n]} E \left\{ \left[ \sum_{k=0}^{D+M-1} \tilde{h}[k] x[n+D-k] \right]^2 \right\}$$

• See Demo Cancel Tone.m at web site