

Extremely Sensitive Ultrashort Pulse Measurement with Chirped Aperiodically Poled Lithium Niobate (A-PPLN) Waveguides



Shang-Da Yang, and Andrew M. Weiner
Purdue University

Krishnan R. Parameswaran, and Martin M. Fejer
Stanford University

Highlight

- Goal: Substantially lower the minimum power requirements for nonlinear pulse duration measurements, especially for optical communications using femtosecond pulses.
- Nonlinear autocorrelation of optical pulses with 220 fs duration, and **52 aJ** coupled pulse energy (**400 photons**) is carried out.
- By chirping the poling period of LiNbO_3 waveguides, we broaden the SHG bandwidth to get distortion-free measurements.

Autocorrelation Sensitivity Comparison

Measurement Technology	Sensitivity [*]	Ref.
Bulk crystal, SHG	0.1~10 (mW) ²	[†]
Silicon avalanche photodiode, TPA	1.5×10 ⁻³ (mW) ²	[‡]
InGaAsP laser diode, TPA	1.5×10 ⁻⁴ (mW) ²	[†]
Chirped A-PPLN waveguide, SHG	3.2 × 10⁻⁷ (mW)²	

[*] Sensitivity is defined as $p_{peak} \cdot p_{avg}$ of the minimum detectable input,
the lower the better!

† J D. Harvey, J M. Dudley, L P. Barry, OFC, 1999

‡ C. Xu, J M. Roth, W H. Knox, K. Bergman, Electronics Letters. 38(2), 2002

Intensity Autocorrelation Measurement

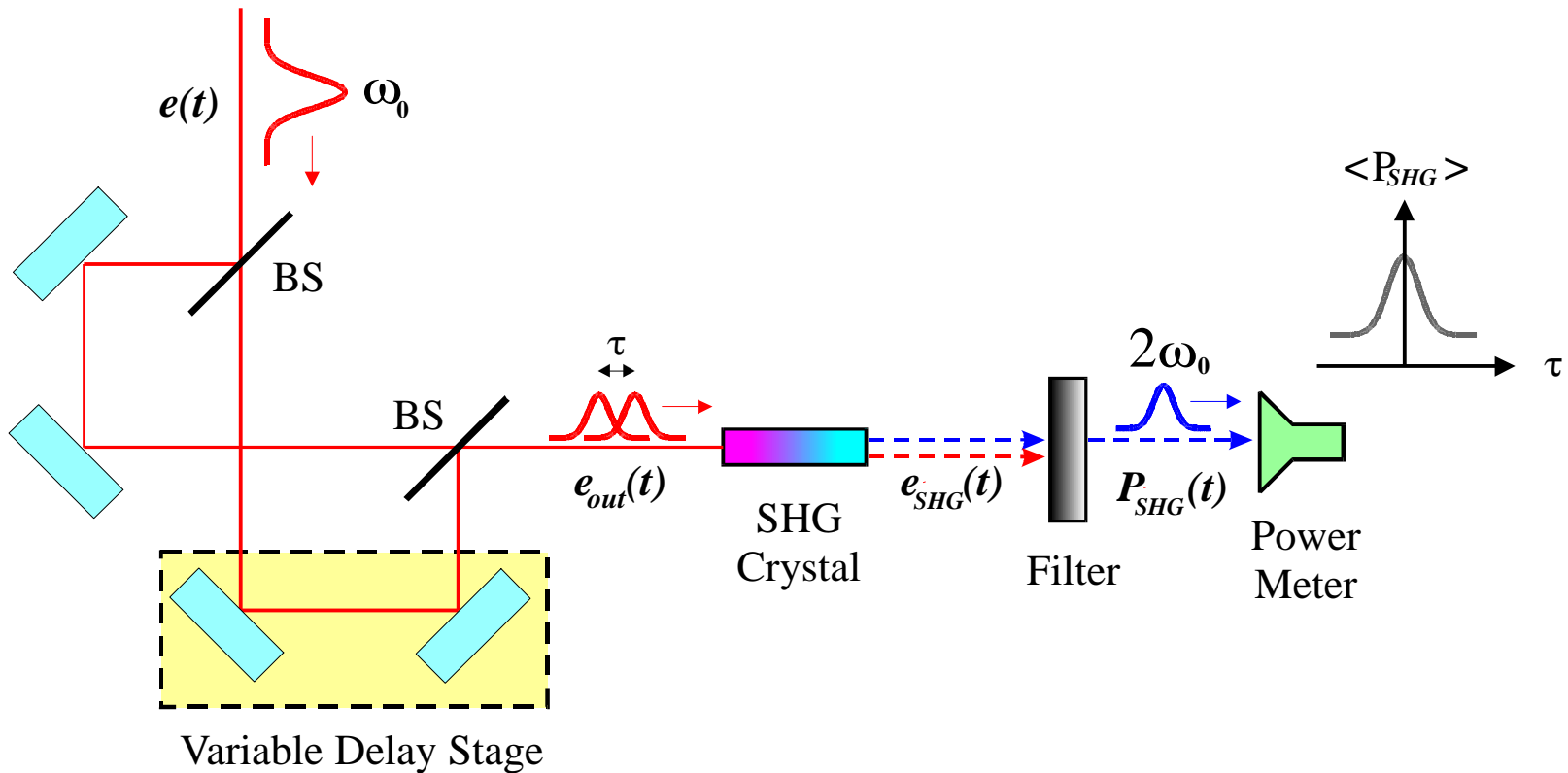

Waveguides Improve SHG Efficiency

- ⇒ Smaller A_{eff} and longer L permit higher SHG efficiency and better measurement sensitivity

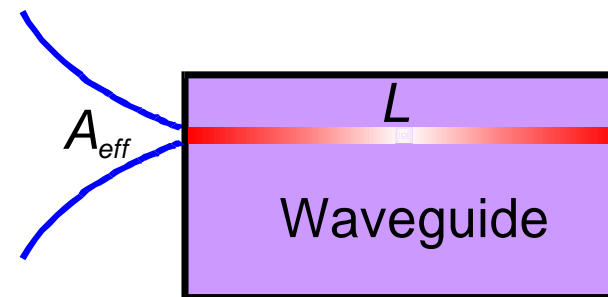
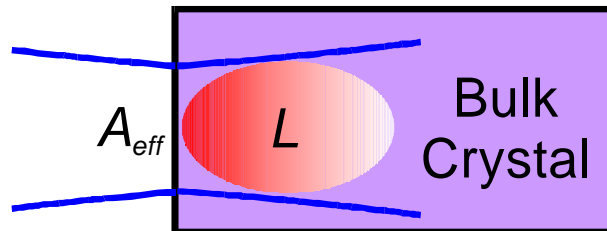
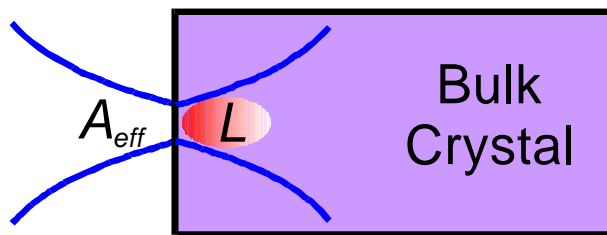

- Gaussian beam diffraction prevents the coexistence of small A_{eff} and long L

- Waveguides enable both small A_{eff} and long L
- QPM technique for SHG in waveguides is the best available one in telecom.

SHG Bandwidth– Concept

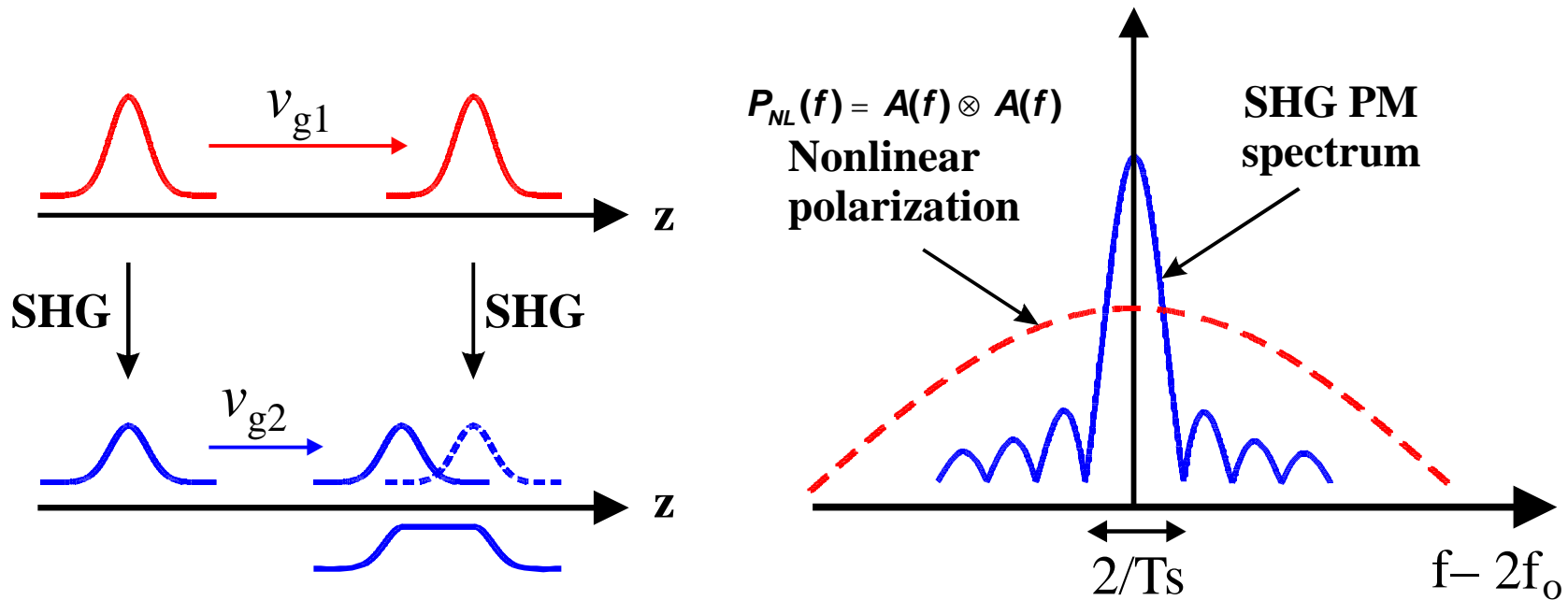

- **GVM:** $T_s \propto \Delta(v_g^{-1}) \cdot L$
- Thick crystal inherits large GVM

- **SHG BW:** $(\Delta f) \propto 1/L$
- Insufficient SHG BW causes measurement distortion

SHG Bandwidth- Improved by Engineering

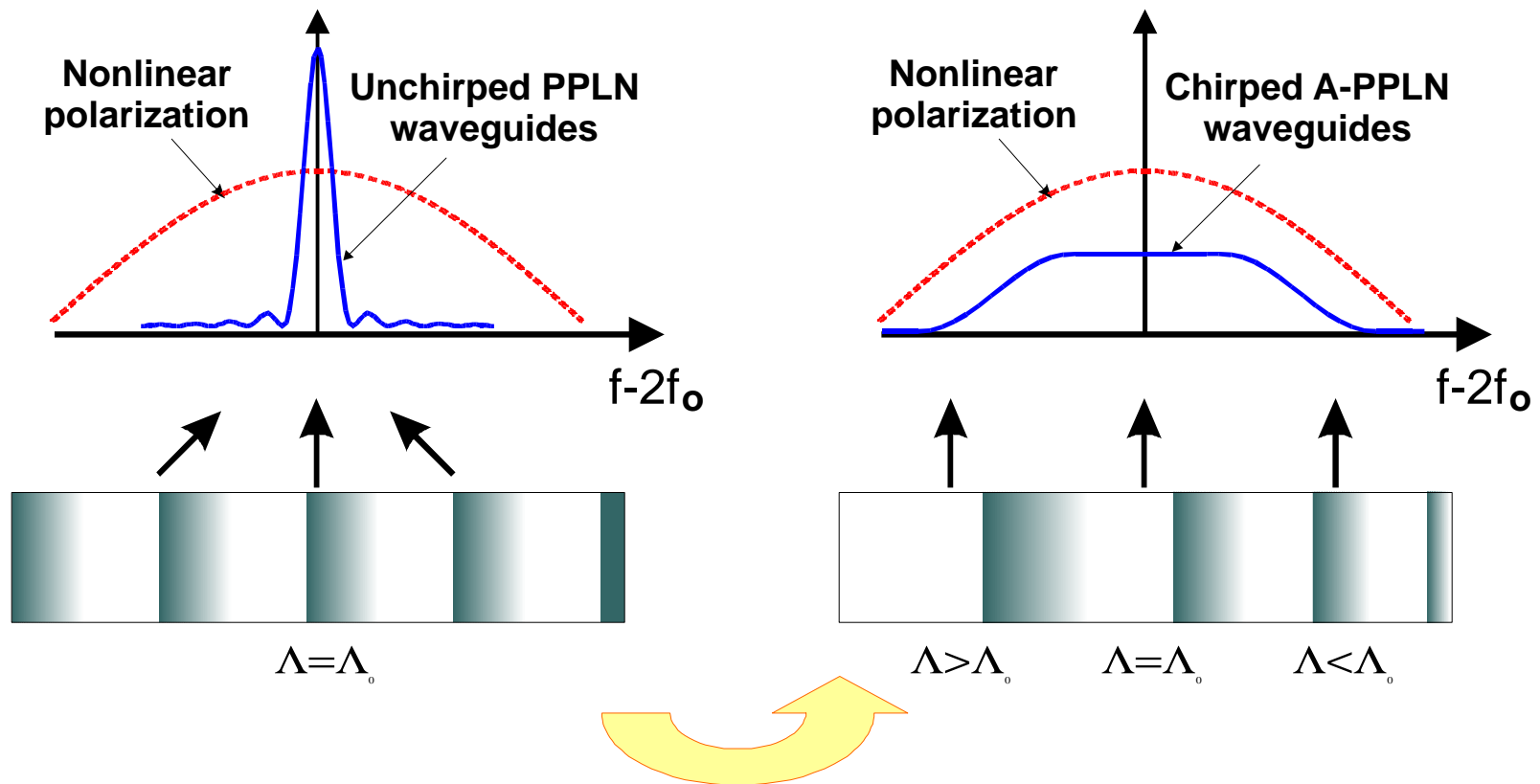

Broadening SHG spectrum by longitudinally chirping the poling period [†]

† G. Imeshev et. al, J. Opt. Soc. Am. B, 17(2), 2000

Efficiency and Bandwidth Trade-off

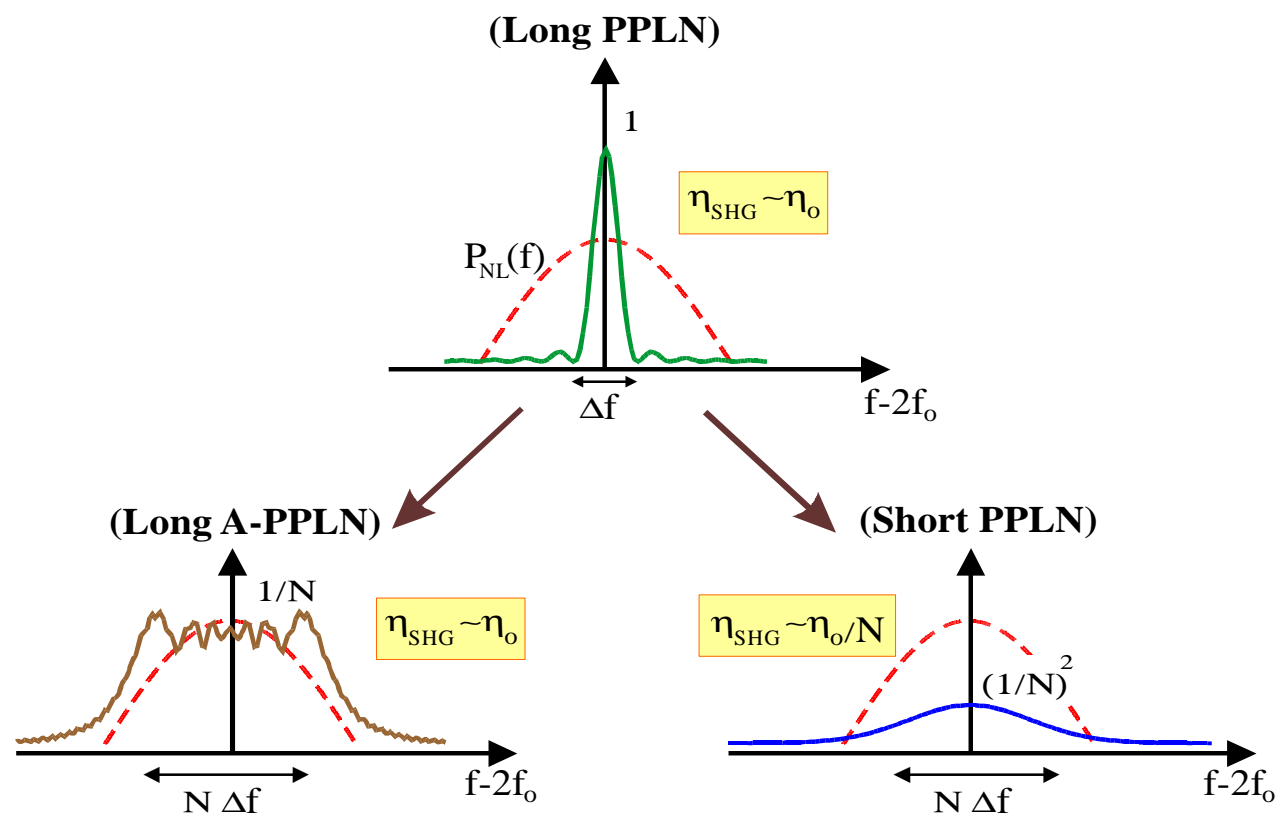

- Short PPLN improves SHG BW, but degrades efficiency
- Long A-PPLN improves SHG BW, and preserves efficiency

SHG Spectra Characterizations

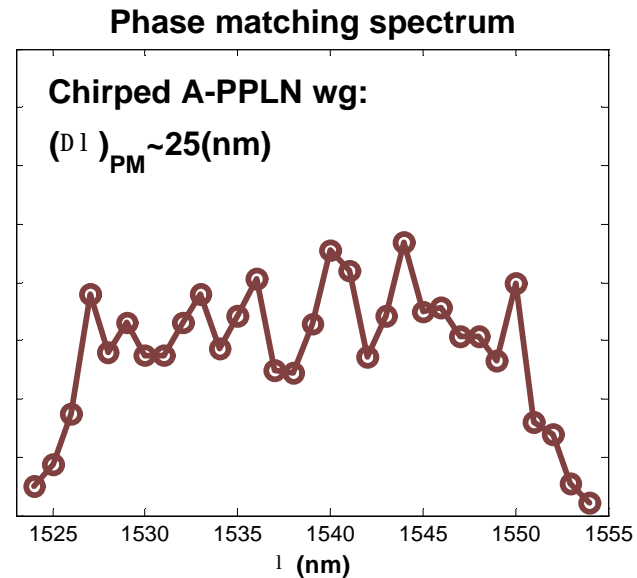
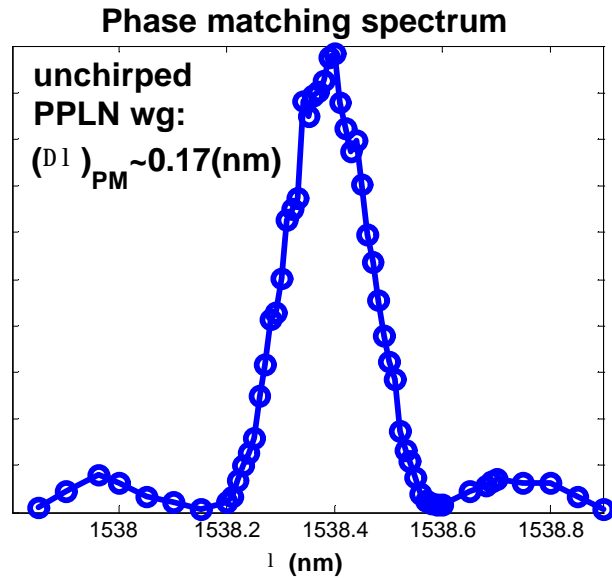
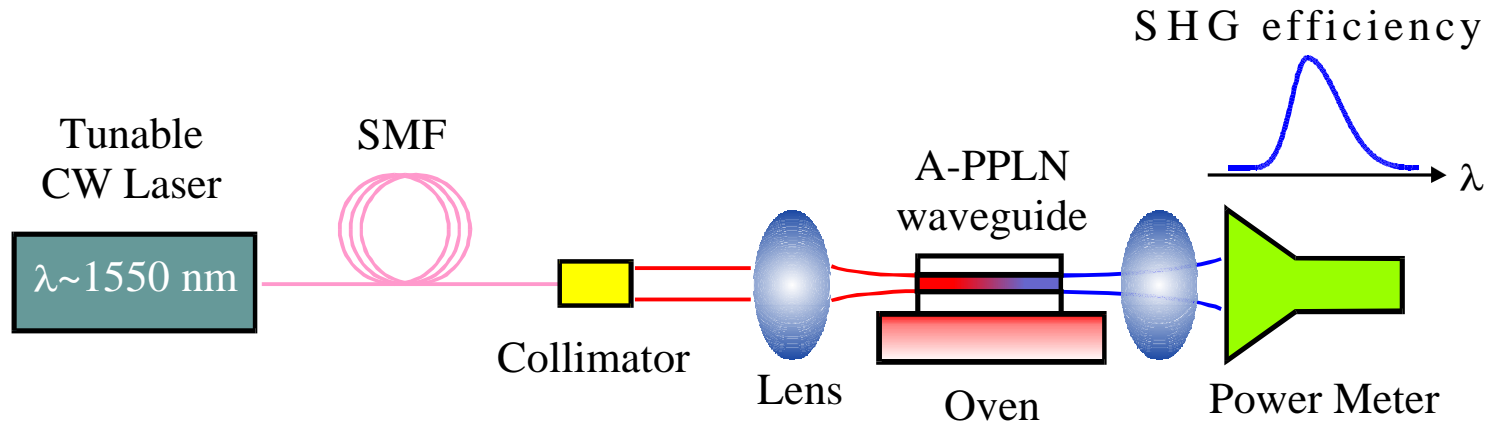

Collinear Autocorrelator Setup

Mode-locked fiber laser:
 $\Delta t \sim 220$ (fs), $f_{\text{rep}} = 50$ (MHz)
 $\lambda_0 = 1545$ (nm), $\Delta\lambda = 13$ (nm)

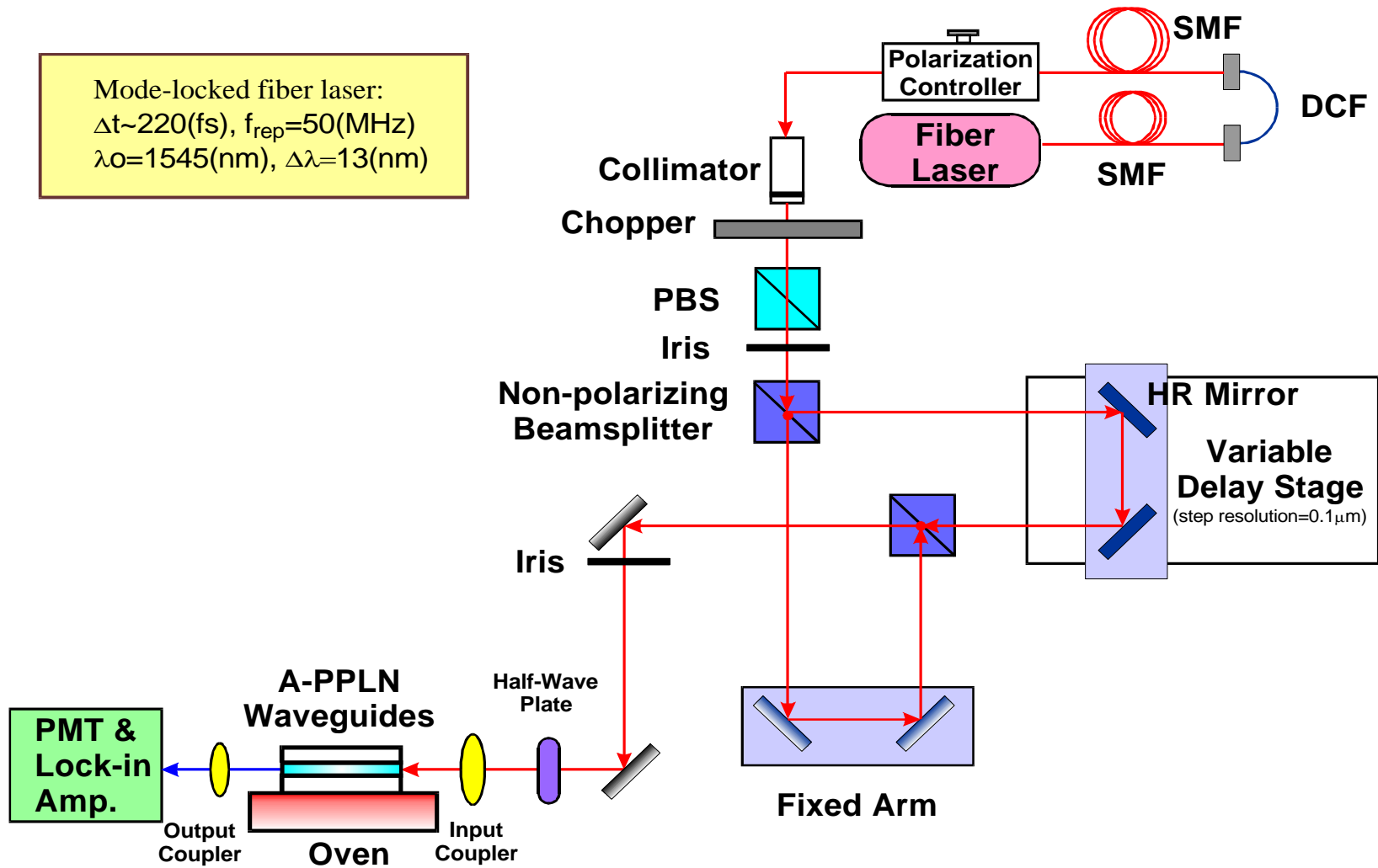

Experimental Result – New Sensitivity Record

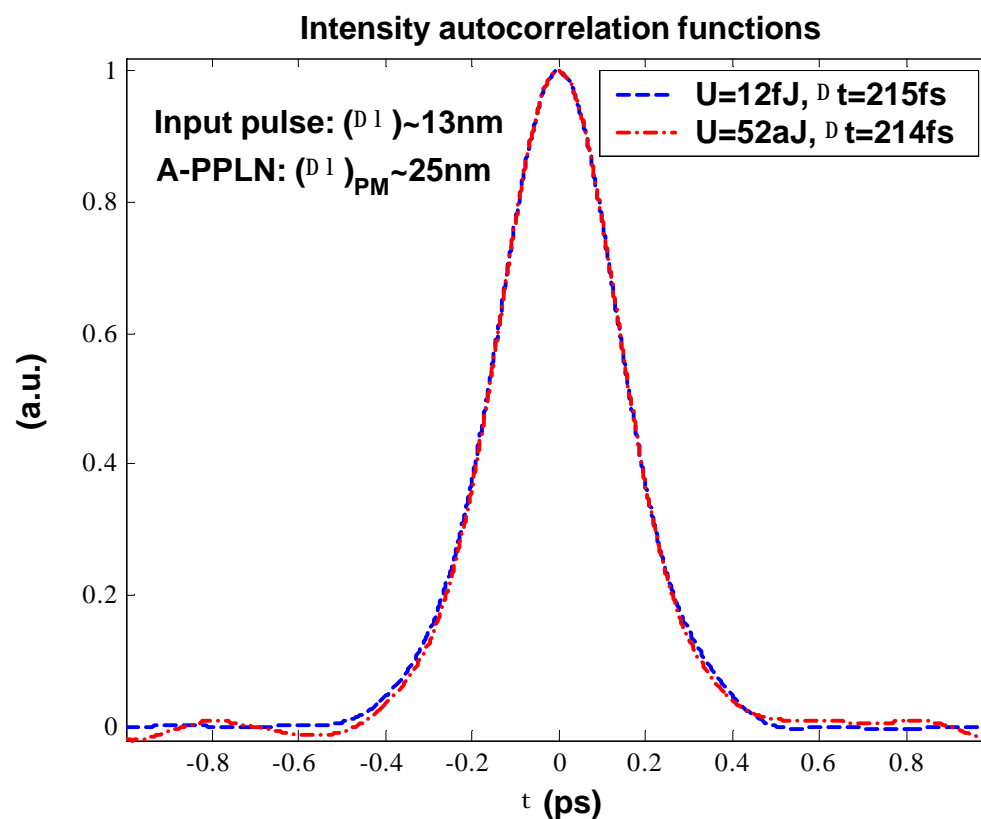

- Coupled input powers: 290nW, 1.3nW
- Corresponding sensitivities:
 $1.6 \times 10^{-3} (\text{mW})^2$, **$0.32 (\text{mW})^2$**
- Data acquisition time < 3min.

Experimental Result – Comparison with Traces by Thin LiIO_3 Bulk Crystal

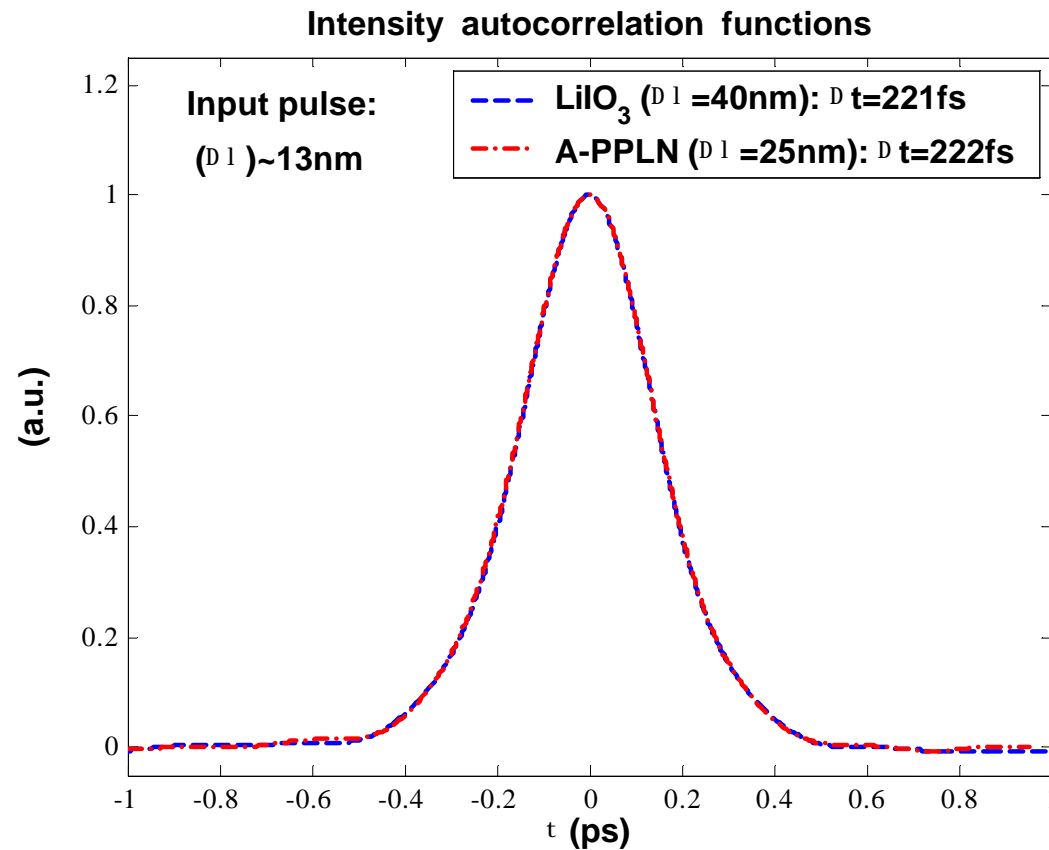

Summary

- We experimentally demonstrate the ultra-sensitive nonlinear autocorrelation using A-PPLN waveguides. The sensitivity is **0.32 (mW)²**, about **500 times** better than the previous record.
- Chirped A-PPLN waveguides with phase matching bandwidth comparable with that of input pulse is used to avoid SHG efficiency and bandwidth trade-off.
- The A-PPLN waveguides can be further applied to cross-correlation, FROG and SPIDER measurement techniques.