

# **Spatial Chirp Effect in Virtually Imaged Phased Array (VIPA) Wavelength Demultiplexor**

Shijun Xiao, A. M. Weiner  
Purdue University

C. Lin  
Avanex Corporation

Conference on Lasers and Electro Optics 2003  
Baltimore, MD. June 4, 2003

Support From National Science Foundation, Army Research Office

# Outline

---

- **VIPA vs. Diffraction Gratings**
  - Large angular dispersion
  - Low polarization sensitivity  
(M. Shirasaki, Optics Letter 1996)
  - Chromatic dispersion compensation  
(M. Shirasaki, IEEE Photonics Tech. Letter 1997 and OFC 2001)
- **VIPA Demultiplexor Spectrum**
  - Review of previous publication
  - Symmetric and asymmetric VIPA demultiplexor spectrum
  - Spatial chirp effect

# VIPA vs. Diffraction Gratings

---

## ➤ How VIPA functions

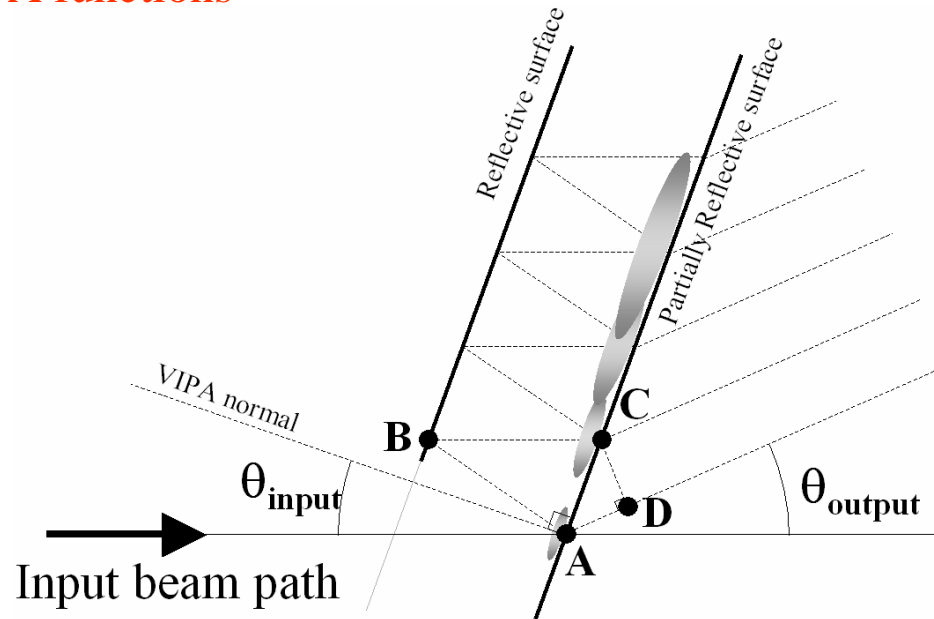

## ➤ Advantages (M. Shirasaki, Optics Letters, Vol. 21, No. 5, March 1, 1996)

- ✓ VIPA has a 10- 20 times larger angular dispersion than common gratings, which is proportional to  $ctg(\theta_{input})$
- ✓ VIPA has a low polarization sensitivity, simple structure, low cost, and compactness

# VIPA Wavelength Demultiplexor

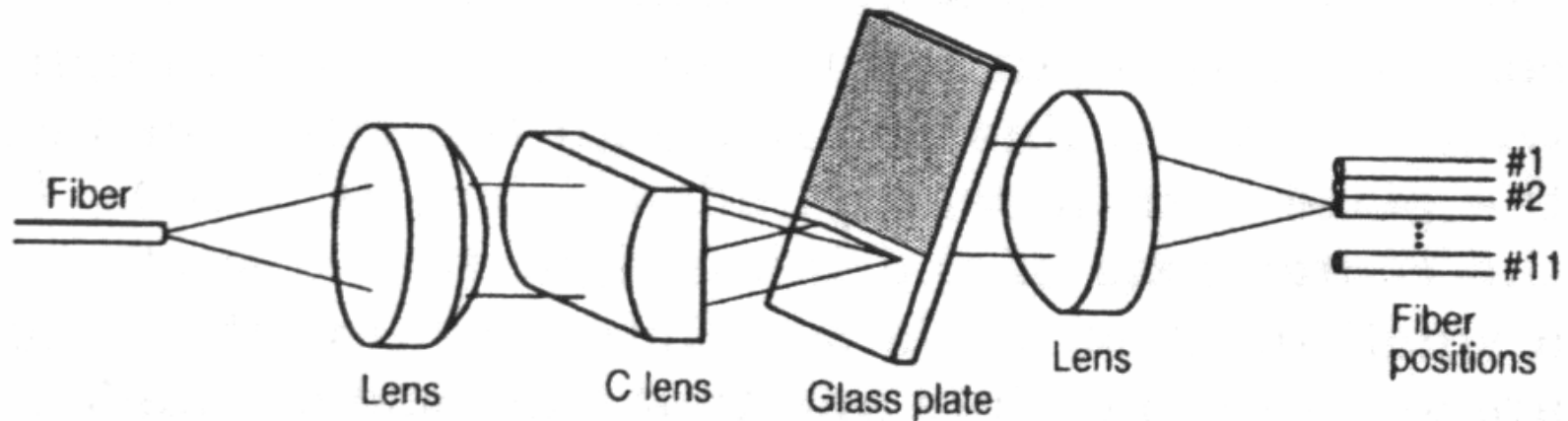

(M. Shirasaki, Optics Letters, Vol. 21, No. 5, March 1, 1996)

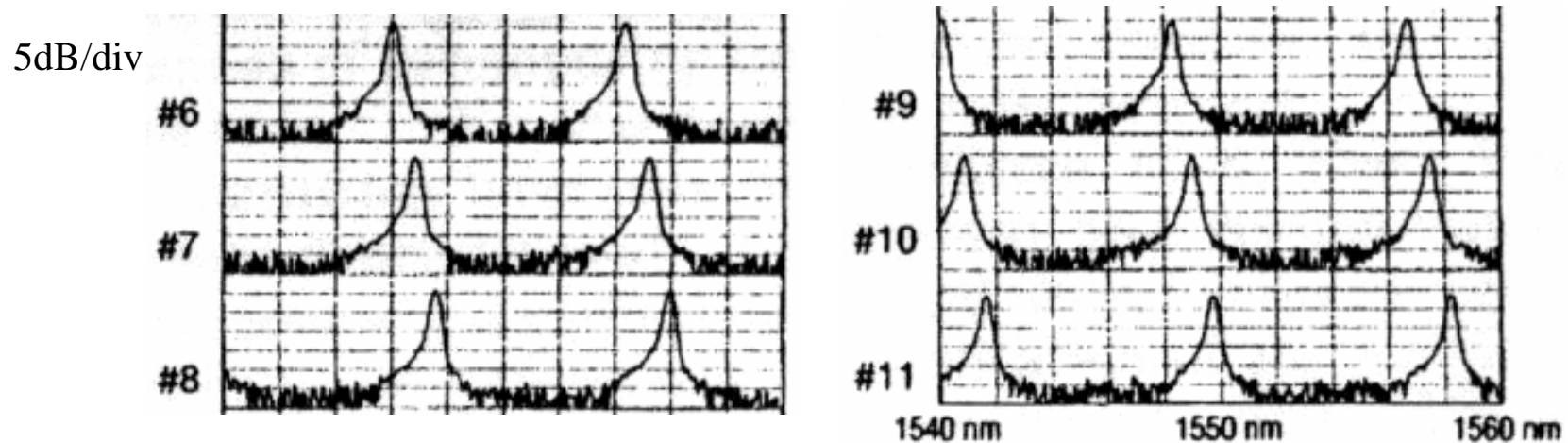

Same phenomena in A. Vega, A. M. Weiner, C. Lin, Applied Optics, In Press

# VIPA Theory Model

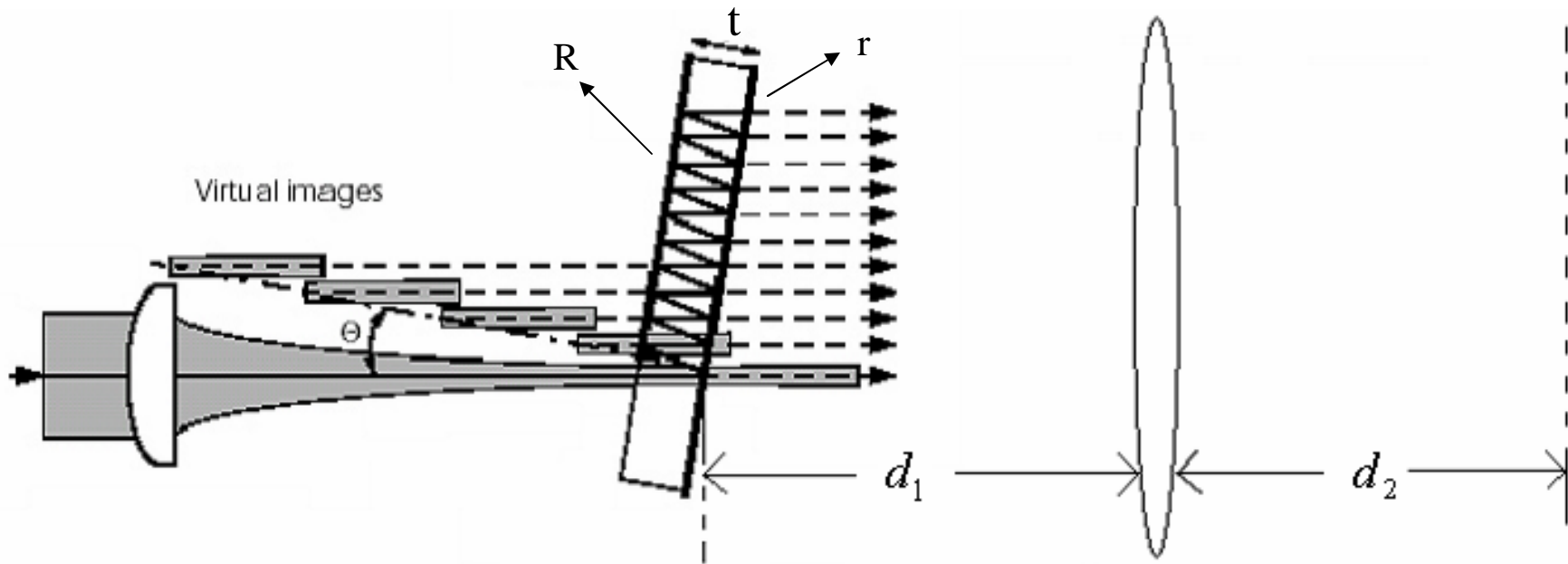

- Each source has a non-chirp Gaussian profile  $E_0 \exp\left(-\frac{x^2}{w_0^2}\right)$
- The  $n$ th source has profile ( $n= 0, 1, 2, \dots$ )

$$E_0 (Rr)^n \exp\left[-\frac{(x - n2t \sin \theta)^2}{w_0^2}\right] \quad d_{1_n} = F + n2t \cos \theta$$

# Theory of VIPA Demultiplexor Spectrum

---

- General Lens Transformation

$$E_{out}(x_F, \lambda) \propto \exp\left[-i \frac{k}{2d_2} \left(\frac{1}{qd_2} + 1\right) x_F^2\right] \int E_{in}(x) \exp\left[-i \frac{k}{2d_1} \left(\frac{1}{qd_1} + 1\right) x^2\right] \exp\left(-i \frac{kx_F x}{qd_1 d_2}\right) dx$$

$$q = \frac{1}{F} - \frac{1}{d_1} - \frac{1}{d_2}$$

- The field at the origin of the receiving plane

$$E_{out}(\lambda) \propto \sum_n (Rr)^n \exp[-ikn2t \cos(\theta_i)] \exp[-ib4n^2 t^2 \sin^2(\theta_i)]$$

$$b = \frac{k}{2d_1} \left(1 + \frac{1}{qd_1}\right) = \frac{k}{2} \frac{d_2 - F}{d_1 d_2 - d_1 F - d_2 F}$$

- The demultiplexor spectrum is very sensitive on  $d_2$  within the focal depth region.
- The spectrum is only weakly dependent on  $d_1$ .

# VIPA Demultiplexor Power Spectrum

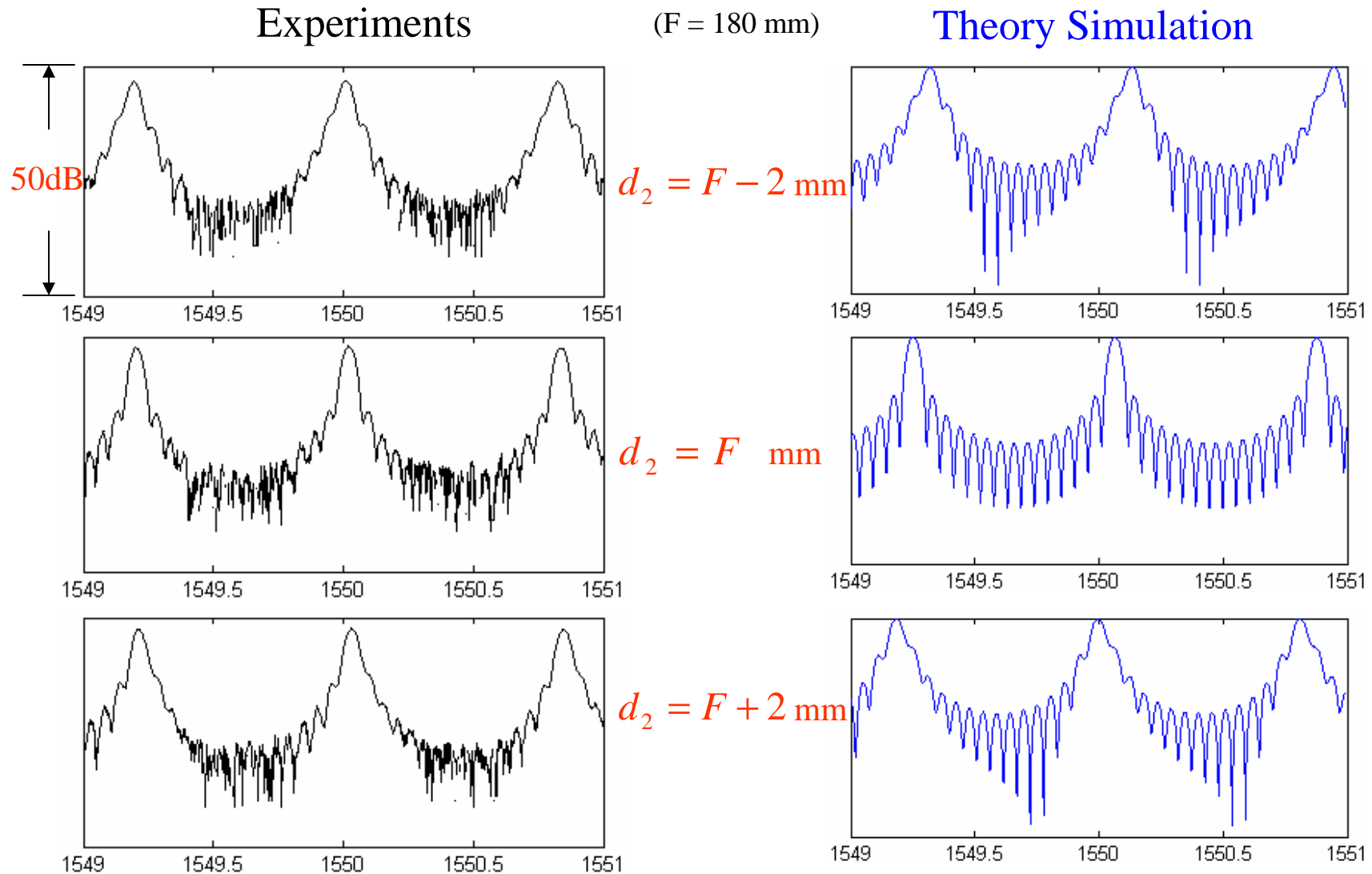

# Our Setup with Spatial Gate

---

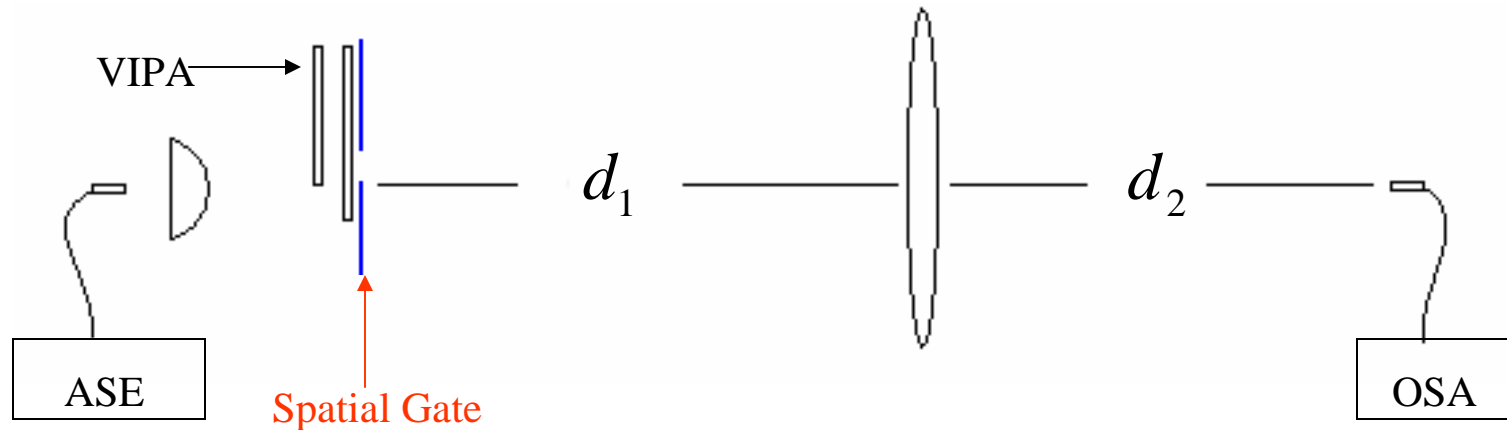

ASE: Amplified Spontaneous Emission; OSA: Optical Spectrum Analyzer  
OSA resolution is 0.01 nm

- We introduce a spatial gate to look at the contribution from different sets of multiple beam spots
- The setup allows us to have a closer look how spectral asymmetry occurs

# Gated Power Spectrum

## Experiments

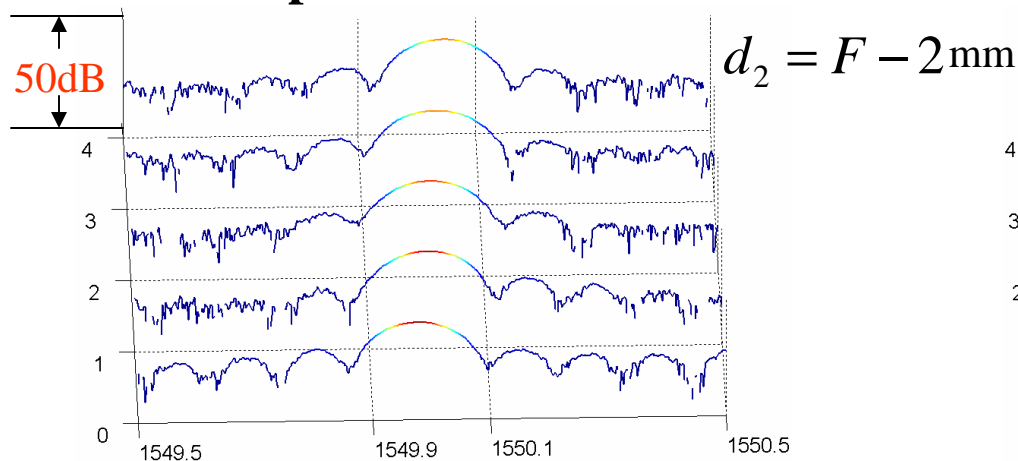

## Theory Simulation

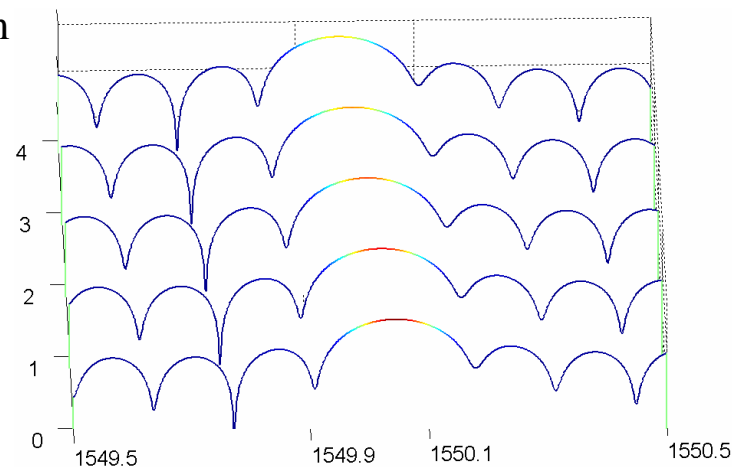
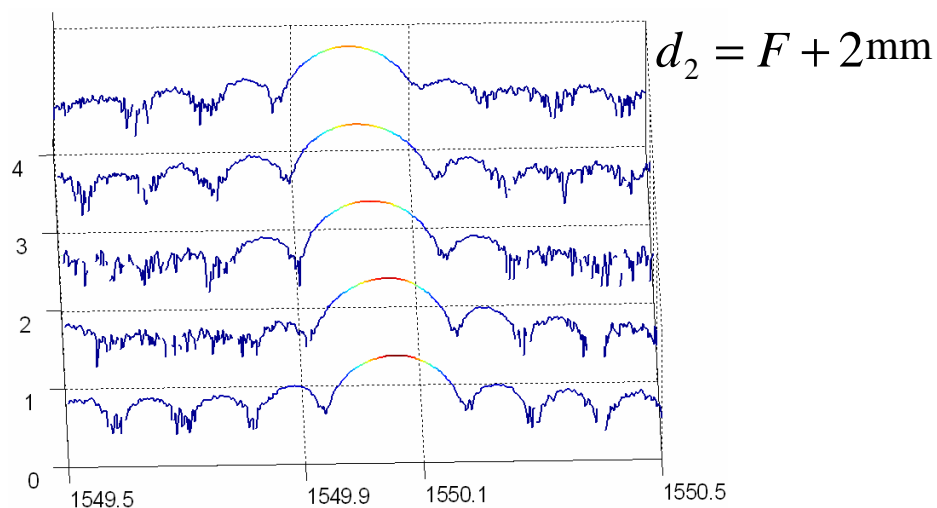
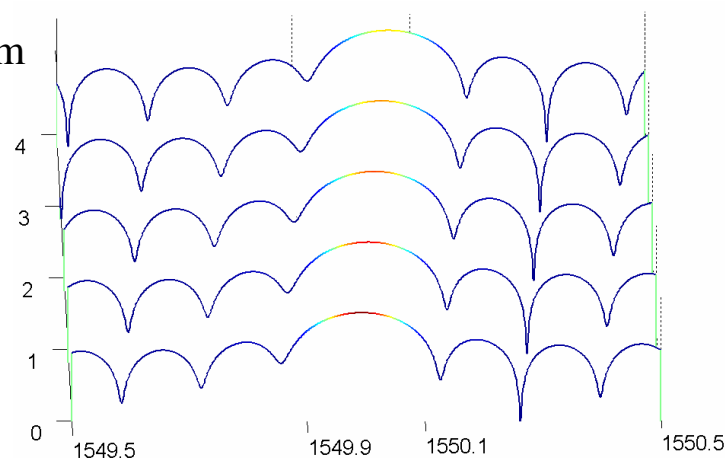

# Asymmetry Effects

## Experiments

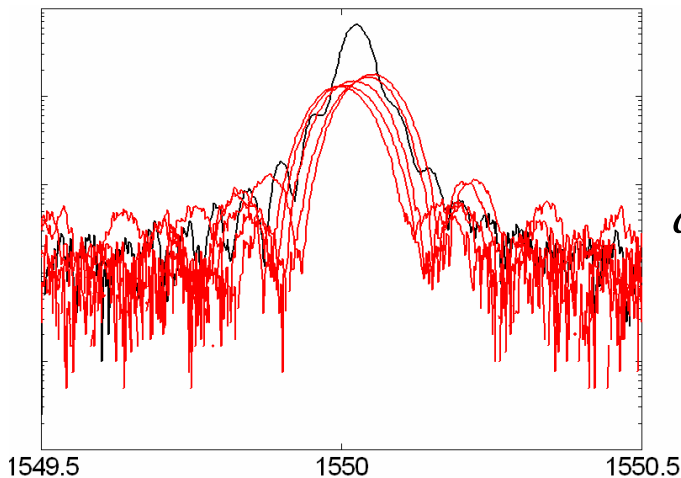
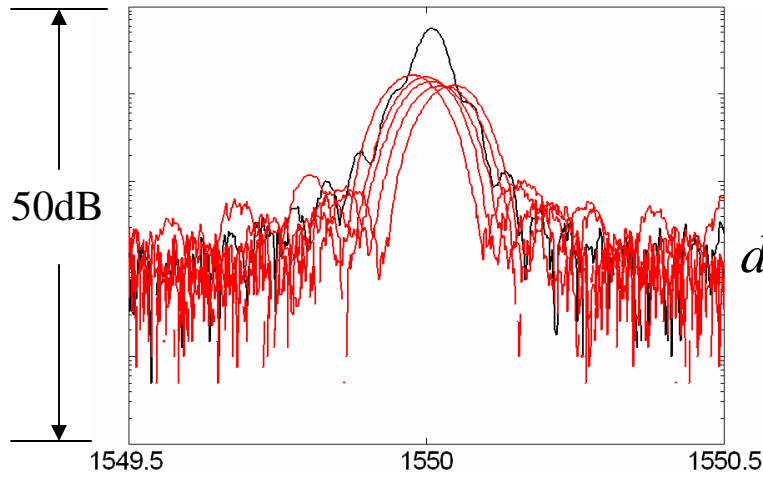

## Theory Simulation

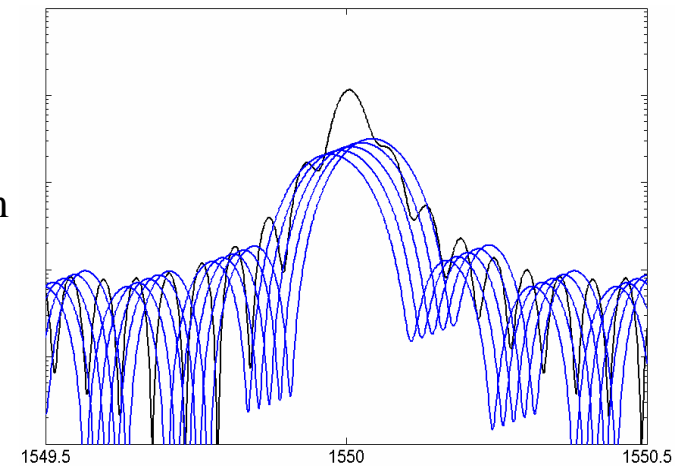
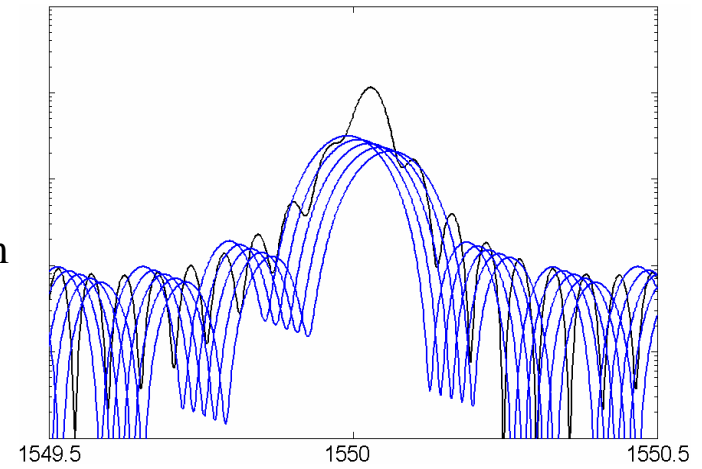

( $F = 180 \text{ mm}$ )

# Symmetry and Discussions

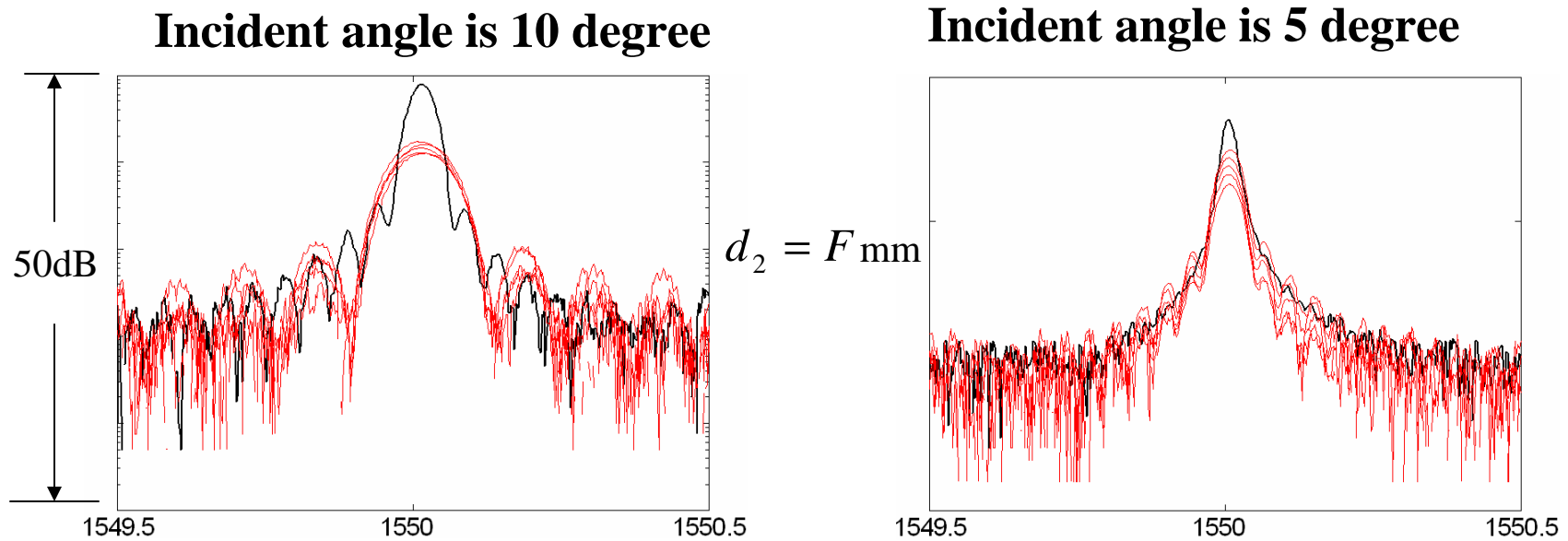

$F = 180$  mm

- We can obtain spatial chirp-free spectrum when  $d_2 = F$
- Line-shape asymmetry when  $d_2 \neq F$  is associated with spatial chirp effect

( $d_2$  is the longitudinal distance between the focusing lens and the receiver)

# Summary

---

- We explain the **symmetric behavior** of VIPA demultiplexor line-shape  
Spectral symmetry or asymmetry strongly depends on receiver's longitudinal position
- We identify a **spatial chirp effect** strongly related to line-shape asymmetry
- Our results are fully explained by our theory