

ECE 302
Homework 3, due in class Wednesday, 2/4/2004.

Reading: Last subsection of Section 1.5, Sections 1.6-2.2 (pages 41-79); corresponding practice problems in the book (solutions are available at <http://www.athenasc.com/probsolved.pdf>).

Problem 1. An internet access provider (IAP) owns two servers. Each server has a 50% chance of being “down” independently of the other. Fortunately, only one server is necessary to allow the IAP to provide service to its customers, i.e., only one server is needed to keep the IAP’s system up. Suppose a customer tries to access the internet on four different occasions, which are sufficiently spaced apart in time, so that we may assume that the states of the system corresponding to these four occasions are independent. What is the probability that the customer will only be able to access the internet on three out of the four occasions?

Problem 2. A subway train made up of n cars is boarded by r passengers ($r \leq n$), each passenger choosing a car at random (using the discrete uniform probability law) and independently of other passengers. What is the probability of the passengers all ending up in different cars?

Problem 3. A wooden cube with painted faces is sawed up into 1000 little cubes, all of the same size. The little cubes are then mixed up, and one is chosen at random. What is the probability of its having exactly two painted faces?

Problem 4. Suppose n people sit down at random and independently of each other in an auditorium containing $n + k$ seats. What is the probability that m seats specified in advance ($m \leq n$) will be occupied?

Problem 5. Suppose you are interviewing people for the position of ECE 302 instructor for Fall 2004. You have four candidates who are interviewed consecutively: 1, 2, 3, and 4. If you interview any two of them, you will be able to determine which one of the two is better. The problem is, you are required to tell the decision to each candidate at the end of his/her interview: you either reject the candidate and go on to the next candidate, or you hire the candidate and reject all the remaining candidates without interviewing them. If you reject the first three candidates, you must hire the fourth. Before the interviews start, you have no information about the relative strength of the candidates, and so you assume that the best candidate is equally likely to be candidate 1, 2, 3 or 4; the second-best candidate is also equally likely to be candidate 1, 2, 3, or 4, etc.

- (a) Suppose your strategy is to hire the candidate 1, regardless of what happens during his/her interview. What is the probability that you will hire the best candidate?
- (b) Suppose you interview and reject candidate 1, and then continue the interviews and hire the first candidate you see who is better than candidate 1. I.e., if candidate 2 is better than candidate 1, you hire candidate 2; if candidate 2 is worse than candidate 1 then you interview candidate 3. If you interview candidate 3, then: if he is better than candidate 1, you hire candidate 3, otherwise you hire candidate 4. What is the probability that you will hire the best candidate?
- (c) Suppose you interview and reject first two candidates, and then hire candidate 3 if he is better than both candidates 1 and 2, and hire candidate 4 otherwise. What is the probability that you will hire the best candidate?

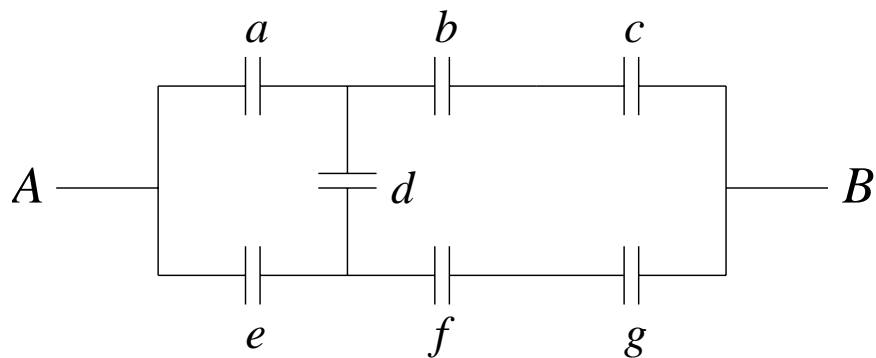

Figure 1: Communication network for Problem 6.

Problem 6. In the communication network of Fig. 1, link failures are independent, and each link has a probability of failure of p . Consider the physical situation before you write anything. A can communicate with B as long as they are connected by at least one path which contains only in-service links. (**Note:** $a, b, c, d, e, f,$ and $g,$ are just the names of the links, NOT probabilities.)

- (a) Given that exactly four links have failed, determine the conditional probability that A can communicate with B .
- (b) Given that exactly four links have failed, determine the conditional probability that either g or f (*but not both*) is still operating properly.
- (c) Given that $a, b,$ and c have failed (but no information about the condition of other links), determine the conditional probability that A can communicate with B .

Problem 7. A poker hand consists of five cards. The different possible hands, from the lowest to the highest, are:

- One pair: two cards of different suits which have the same denominations, e.g., two Queens or two 10's etc.
- Two pair: e.g., two 5's and two 10's.
- Three of a kind: e.g., three 10's.
- Straight: five consecutive cards, which are not all of the same suit. An Ace can play either high or low, as in A-2-3-4-5 or 10-J-Q-K-A, but not both—i.e., for example, Q-K-A-2-3 is not a straight.
- Flush: five cards of the same suit which are not all consecutive.
- Full house: three of a kind and one pair.
- Four of a kind.
- Straight flush: five consecutive cards in the same suit.

Suppose we draw five cards at random from a deck of 52 cards.

- (a) What is the probability to get one pair? (**Hint.** First, note that a hand like 10-10-2-2-3 is not a pair but two pair, 10-10-2-2-2 is a full house, 10-10-10-2-3 is three of a kind, and 10-10-10-10-2 is four of a kind. Conclude therefore that, in order for a hand to be one pair, the pair and each of the three remaining cards must have four distinct denominations. Count the number of ways to choose these four denominations out of 13 possible denominations; then count the number of ways to choose a pair in one of the denominations and a single card in each of the remaining three.)
- (b) What is the probability to get two pair?
- (c) What is the probability to get a straight? (**Hint.** Keep in mind that, for example, 2-3-4-5-6 of clubs is not a straight but a straight flush.)
- (d) What is the probability to get a flush? (**Hint.** Again, keep in mind that, for example, 2-3-4-5-6 of clubs is not a flush but a straight flush.)